

–weishaupt–

# manual

Installation and operating instruction

---

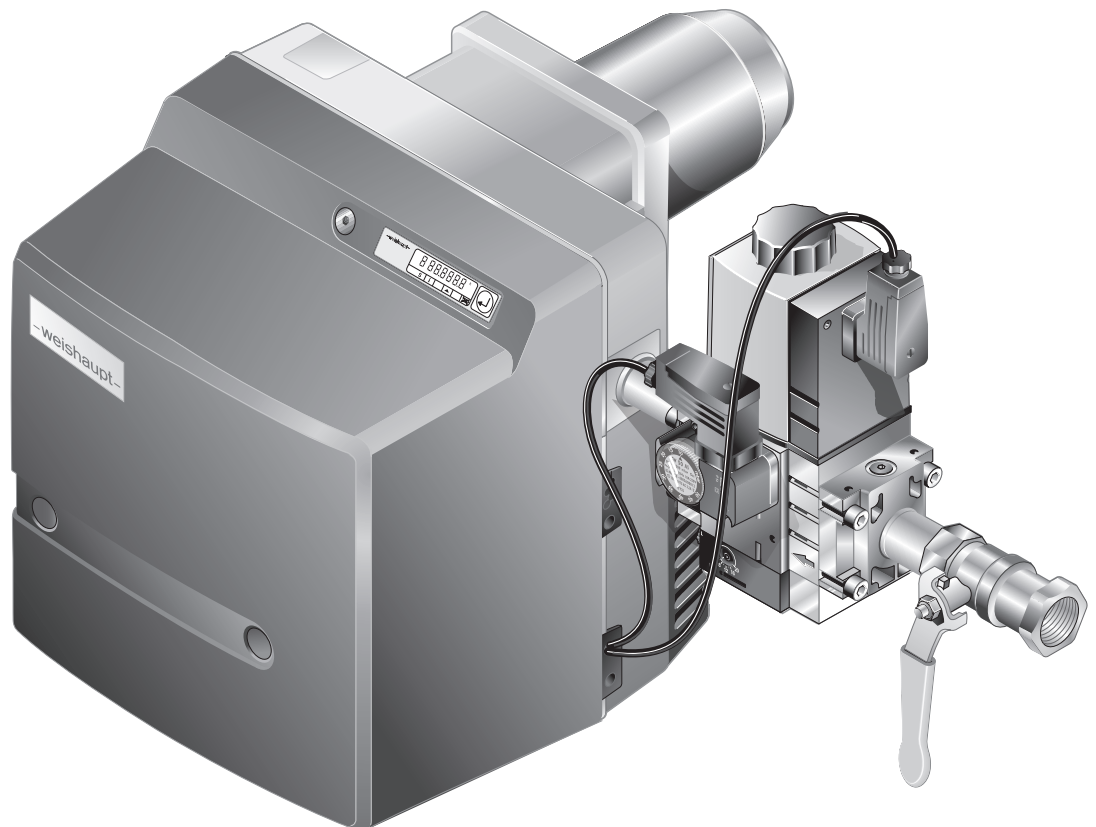

<b>1</b>	<b>User instructions .....</b>	<b>5</b>
1.1	Target group .....	5
1.2	Symbols in the manual .....	5
1.3	Guarantee and Liability .....	6
<b>2</b>	<b>Safety .....</b>	<b>7</b>
2.1	Designated application .....	7
2.2	Safety symbols on the device .....	7
2.3	When gas can be smelled .....	7
2.4	Safety measures .....	8
2.4.1	Personal protective equipment (PPE) .....	8
2.4.2	Normal operation .....	8
2.4.3	Electrical work .....	8
2.4.4	Gas supply .....	9
2.5	Alterations to the construction of the equipment .....	9
2.6	Noise emission .....	9
2.7	Disposal .....	9
<b>3</b>	<b>Product description .....</b>	<b>10</b>
3.1	Type key .....	10
3.2	Type and serial number .....	10
3.3	Function .....	11
3.3.1	Air supply .....	11
3.3.2	Gas supply .....	12
3.3.3	Electrical components .....	13
3.3.4	Program sequence .....	14
3.3.5	Inputs and outputs .....	16
3.4	Technical data .....	17
3.4.1	Approval data .....	17
3.4.2	Electrical data .....	17
3.4.3	Ambient conditions .....	17
3.4.4	Permissible fuels .....	17
3.4.5	Emissions .....	18
3.4.6	Rating .....	19
3.4.7	Dimensions .....	20
3.4.8	Weight .....	21
<b>4</b>	<b>Installation .....</b>	<b>22</b>
4.1	Installation requirements .....	22
4.2	Burner installation .....	23
4.2.1	Rotate burner by 180° (optional) .....	24
<b>5</b>	<b>Installation .....</b>	<b>25</b>
5.1	Gas supply .....	25
5.1.1	Installing the gas valve train .....	26
5.1.2	Carry out soundness test of gas supply line and vent .....	28
5.2	Electrical connection .....	29

<b>6</b>	<b>Operation .....</b>	<b>30</b>
6.1	Operating panel .....	30
6.2	Display .....	32
6.2.1	Info level .....	33
6.2.2	Service level .....	34
6.2.3	Parameter level .....	35
6.2.4	Access level .....	37
6.3	Linearisation .....	38
<b>7</b>	<b>Commissioning .....</b>	<b>39</b>
7.1	Prerequisite .....	39
7.1.1	Connect measuring devices .....	40
7.1.2	Check gas connection pressure .....	41
7.1.3	Check soundness of gas valve train .....	42
7.1.4	Purging the gas valve train .....	45
7.1.5	Preset pressure regulator .....	46
7.1.6	Setting values .....	48
7.1.7	Preset gas and air pressure switch .....	49
7.2	Adjusting the burner .....	50
7.2.1	Burner without variable speed drive .....	50
7.2.2	Burner with variable speed drive (optional) .....	57
7.3	Set pressure switches .....	65
7.3.1	Set gas pressure switch .....	65
7.3.2	Set air pressure switch .....	66
7.4	Concluding work .....	67
7.5	Check combustion .....	68
7.6	Calculate gas throughput .....	69
7.7	Subsequent optimisation of operating points .....	70
<b>8</b>	<b>Shutdown .....</b>	<b>71</b>
<b>9</b>	<b>Servicing .....</b>	<b>72</b>
9.1	Notes on servicing .....	72
9.2	Service plan .....	74
9.3	Removing and refitting mixing head .....	75
9.4	Set mixing head .....	76
9.5	Set ionisation and ignition electrodes .....	77
9.6	Service position .....	78
9.7	Removing and refitting fan wheel .....	79
9.8	Remove burner motor .....	79
9.9	Removing and refitting air damper actuator .....	80
9.10	Removing and refitting angle drive .....	81
9.11	Removing and refitting gas butterfly valve actuator .....	82
9.12	Removing and refitting gas butterfly valve .....	83
9.13	Removing and refitting air regulator .....	84
9.14	Replacing coil on multifunction assembly .....	85
9.15	Replace breather plug of multifunction assembly .....	86
9.16	Removing and refitting filter insert of multifunction assembly .....	87
9.17	Replacing the combustion manager .....	88
9.18	Replacing the fuse .....	91

<b>10</b>	<b>Troubleshooting .....</b>	<b>92</b>
10.1	Procedures for fault conditions .....	92
10.1.1	Display off .....	92
10.1.2	Display OFF .....	92
10.1.3	Display flashes .....	93
10.1.4	Detailed fault codes .....	94
10.2	Rectifying faults .....	95
10.3	Operating problems .....	99
<b>11</b>	<b>Technical documentation .....</b>	<b>100</b>
11.1	Program sequence .....	100
11.2	Conversion table unit of pressure .....	102
11.3	Appliance categories .....	103
<b>12</b>	<b>Project planning .....</b>	<b>108</b>
12.1	Continuous running fan or post-purge .....	108
12.2	Additional requirements .....	109
<b>13</b>	<b>Spares .....</b>	<b>110</b>
<b>14</b>	<b>Notes .....</b>	<b>120</b>
<b>15</b>	<b>Key word index .....</b>	<b>121</b>

## 1 User instructions

Translation of original  
operating instructions



This manual forms part of the equipment and must be kept on site.

Carefully read the manual prior to working on the unit.

### 1.1 Target group









The manual is intended for the operator and qualified personnel. It should be observed by all personnel working with the unit.

Work on the unit must only be carried out by personnel who have had the relevant training and instruction.

Persons with limited physical, sensory or mental capabilities may only work on the unit if they are supervised or have been trained by an authorised person.

Children must not play with the unit.

### 1.2 Symbols in the manual

 <b>DANGER</b>	Danger with high risk. Non observance can lead to serious injury or death.
 <b>WARNING</b>	Danger with medium risk. Non observance can lead to serious injury or death.
 <b>CAUTION</b>	Danger with low risk. Non observance can cause injury to personnel.
 <b>NOTICE</b>	Non observance can cause damage to the equipment and environmental damage.
	Important information
	Requires direct action
	Result after an action
	Itemisation
	Range of values or ellipsis
02	Replacement character for digits, e. g. language key for Print No.
Display text	Font for text that appears in the display

## 1 User instructions

### 1.3 Guarantee and Liability

Guarantee and liability claims for personal and equipment damage are excluded, if they can be attributed to one or more of the following causes:

- non approved application
- non-observance of the manual
- operation with faulty safety equipment
- continual operation despite a fault
- improper installation, commissioning, operation and service
- repairs, which have been carried out incorrectly
- the use of non original Weishaupt parts
- force majeure
- unauthorised modifications made to the unit
- the installation of additional components, which have not been tested with the unit
- the installation of combustion chamber inserts, which impede full flame formation
- unsuitable fuels
- defects in the inlet lines

## 2 Safety

### 2.1 Designated application

The burner is suitable for operation on heat exchangers to EN 303 and combustion chambers to EN 676.

If the burner is not used on combustion chambers to EN 303 and EN 676, a safety assessment of combustion and flame stability during individual process conditions, as well as the shutdown limits of the combustion plant has to be carried out and documented.

The Technical data must be adhered to [ch. 3.4].

The combustion air must be free from aggressive compounds (e. g. Halogens). If the combustion air is contaminated, increased cleaning and servicing will be required. In this case ducted air intake is recommended.



The burner should preferably be operated indoors.

If the burner is not operated indoors, weather protection is required to protect from rain and direct sunlight. The ambient conditions must be adhered to [ch. 3.4.3].

Improper use could:

- endanger the health and safety of the user or third parties
- cause damage to the unit or other material assets

### 2.2 Safety symbols on the device

Symbol	Description	Position
	Warning of electrical voltage	Burner housing
	Dangerous electric voltage	Ignition unit

### 2.3 When gas can be smelled

Avoid open flames and spark generation, for example:

- do not operate light switches
- do not operate electronic equipment
- do not use mobile telephones
- ▶ Open doors and windows.
- ▶ Close gas isolation valve.
- ▶ Warn the inhabitants, do not ring door bells.
- ▶ Leave the building.
- ▶ Inform the heating contractor or gas supplier from outside of the building.

2 Safety

**2.4 Safety measures**

Safety relevant fault conditions must be eliminated immediately.

Components, which show increased wear and tear or whose design lifespan is or will be exceeded prior to the next service should be replaced as a precaution.

The design lifespan of the components is listed in the service plan [ch. 9.2].

**2.4.1 Personal protective equipment (PPE)**

Use the necessary personal protective equipment for all work.

Personal protective equipment protects the user when working on the device.

Safety shoes must be worn during all work carried out on the device.

Further necessary PPE is shown in the respective section by a mandatory symbol.

Symbol	Description	Information
	Use hand protection	▶ Wear suitable protective gloves.

**2.4.2 Normal operation**

- All labels on the unit must be kept in a legible condition and replace if necessary.
- Stipulated settings, service and inspection work should be carried out at regular intervals.
- Only operate the unit with its cover closed.
- Ensure combustion air supply is unimpeded.

**2.4.3 Electrical work**

When working on live components please ensure you:

- observe the accident prevention instructions (e. g. DGUV Regulation 3) and adhere to local directives
- use tools in accordance with EN IEC 60900

The device contains components, which could be damaged by electrostatic discharge (ESD).

When working on circuit boards and contacts:

- do not touch circuit boards or contacts
- if necessary, take ESD protective measures



### 2.4.4 Gas supply

- Only the gas supply company or an approved contract installation company may carry out installation, alteration and maintenance work on gas appliances in buildings and properties.
- Pipework must be subject to a combined load and valve proving test and/or usability testing relative to the pressure range intended, e. g. DVGW-TRGI, worksheet G 600.
- Inform the gas supply company about the type and size of plant prior to installation.
- Local regulations and guidelines must be observed during installation, e. g. DVGW-TRGI, worksheet G 600; TRF Band 1 and Band 2.
- The gas supply pipe work should be suitable for the type and quality of gas and should be designed in such a way that it is not possible for liquids to form, e. g. condensate. Observe vaporisation pressure and vaporisation temperature of liquid petroleum gas.
- Use only tested and approved sealing materials, whilst observing all process information.
- Re-commission the appliance when changing to a different type of gas. Changing from LPG to Natural Gas and visa versa requires a conversion.
- Carry out soundness test after each service and fault rectification.

### 2.5 Alterations to the construction of the equipment

All conversions require written approval from Max Weishaupt SE.

- No additional components may be fitted, which have not been tested for use with the equipment.
- Do not use combustion chamber inserts, which hinder flame burnout.
- Use only original Weishaupt replacement parts.

### 2.6 Noise emission

The noise emissions are determined by the acoustic behaviour of all components fitted to the combustion system.

Prolonged exposure to high noise levels can lead to loss of hearing. Provide operating personnel with protective equipment.

Noise emissions can further be reduced with a sound attenuator.

### 2.7 Disposal

Dispose of all materials and components in a safe and environmentally friendly way at an authorised location. Observe local regulations.

### 3 Product description

### 3 Product description

#### 3.1 Type key

Example: WG20N/1-C ZM-LN

##### Type

---

W	Series: Compact burner
G	Fuel: Gas
20	Size
N	N: Natural Gas F: Liquid Petroleum Gas
1	Ratings size
C	Construction stage

##### Version

---

ZM	Type of control: modulating
LN	Mixing head: LowNO <sub>x</sub>

#### 3.2 Type and serial number

The type and serial number on the type plate clearly identify the product. They are required by Weishaupt's customer service department.

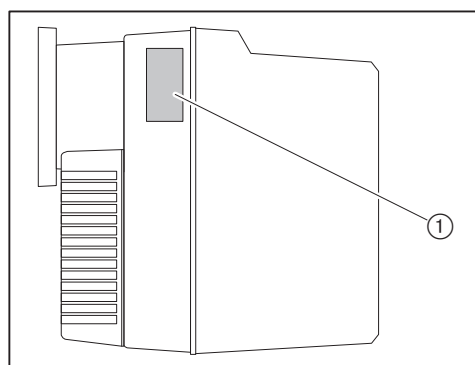

① Name plate

<b>Mod.:</b> _____	<b>Ser. Nr.:</b> _____
--------------------	------------------------

### 3.3 Function

#### 3.3.1 Air supply

##### **Air damper**

The air damper regulates the air quantity required for combustion. The combustion manager drives the air damper via actuator.

At burner shutdown the actuator automatically closes the air damper. This reduces heat loss in the heat exchanger.

##### **Fan wheel**

The fan wheel supplies the air from the air intake housing to the combustion head.

##### **Diffuser**

The air gap between flame tube and diffuser is adjusted by positioning the diffuser. This adjusts the mixing pressure and the air quantity required for combustion.

##### **Air pressure switch**

The air pressure switch monitors the fan pressure. If the fan pressure is insufficient, the combustion manager initiates a lockout.

3 Product description

3.3.2 Gas supply

Gas isolation valve ①

The gas isolation valve opens and shuts off the gas supply.

Multifunction assembly ⑧

The multifunction assembly contains:

Gas filter ②	The gas filter protects the subsequent valve train components from foreign particles.
Double gas valve ④	The double gas valve opens and shuts off the gas supply.
Pressure regulator ③	The pressure regulator reduces the connection pressure and ensures a constant set pressure.

Gas butterfly valve ⑤

The gas butterfly valve regulates the gas quantity depending on the rating required. The combustion manager drives the gas butterfly valve via actuator.

Low gas pressure switch/valve proving gas pressure switch ⑦

The gas pressure switch monitors the gas connection pressure. If the preset pressure is not achieved, the combustion manager initiates a safety shutdown.

The gas pressure switch also monitors if the gas valves are tight. It signals the combustion manager if the pressure increases or decreases to an impermissible level during valve proving.

Valve proving is carried out automatically by the combustion manager:

- after every controlled shutdown
  - prior to burner start following lockout or power outage
1. Test phase (function sequence for valve proving valve 1):
- valve 1 closes
  - valve 2 closes after a delay
  - the gas escapes and the pressure between valve 1 and valve 2 reduces
  - both valves remain closed for 8 seconds

If the pressure increases above the set value during these 8 seconds, valve 1 is leaking. The combustion manager initiates a controlled shutdown.

2. Test phase (function sequence for valve proving valve 2):

- valve 1 opens, valve 2 remains closed
- pressure between valve 1 and valve 2 increases
- valve 1 closes again
- both valves remain closed for 16 seconds

If the pressure decreases below the set value during these 16 seconds, valve 2 is leaking. The combustion manager initiates a controlled shutdown.

### High gas pressure switch ⑥ (optional)

Depending on the burner application, optional equipment may be required for optimum operation [ch. 12.2].

The high gas pressure switch monitors the set pressure. If the set pressure exceeds the set value, the combustion manager initiates a controlled shutdown.

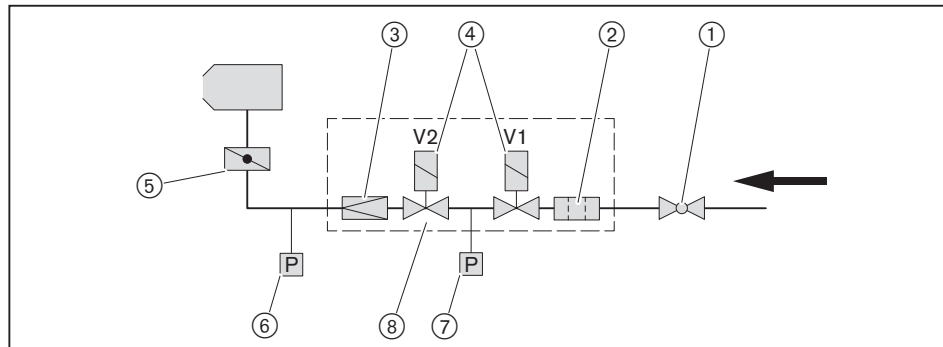

### 3.3.3 Electrical components

#### Combustion Manager

The combustion manager W-FM is the control unit of the burner.

It controls the sequence of operation and monitors the flame.

#### Operating panel

The values and parameters of the combustion manager can be displayed and changed at the operating panel.

#### Burner motor

The burner motor drives the fan wheel.

#### Ignition unit

The electronic ignition unit creates a spark at the electrode, which ignites the fuel/air mixture.

#### Ionisation electrode

The combustion manager monitors the flame signal via the ionisation electrode.

If the flame signal becomes too weak, the combustion manager carries out a controlled shutdown.

**3 Product description**

**3.3.4 Program sequence**

The operating phases for commissioning the burner are shown on the display.

Phase	Function
TEST	After the power supply has been switched on the combustion manager performs a self-test.
G L	At heat demand, the actuators for the air damper and the gas butterfly valve drive to the reference point.
1	The combustion manager monitors for extraneous light.
2	The air damper actuators drives to pre-purge (operating point P9). The gas butterfly valve actuator drives to ignition position (operating point P0).
3	Pre-purge is initiated. The air pressure switch reacts.
4	Pre-purge. The remaining pre-purge time is displayed.
5	The air damper actuator drives to ignition position (operating point P0).
6	Gas valve 1 opens. The gas pressure switch reacts. Ignition starts.
7	Gas valve 2 opens. The fuel is released. The safety time begins. The display shows symbol  .
8	Flame stabilisation.
9	The actuators for the air damper and gas butterfly valve drive to partial load.
10	The burner is in operation. Load control is activated.
11	If heat demand is no longer available, the actuators for air damper and gas butterfly valve drive to partial load. The fuel supply is shut off. The burner motor continues to run. Valve proving starts. 1. Test phase (function sequence for valve proving valve 1): <ul style="list-style-type: none"> <li>▪ valve 1 closes</li> <li>▪ valve 2 closes after a delay</li> <li>▪ the gas escapes and the pressure between valve 1 and valve 2 reduces</li> </ul>
12	Test time valve 1.
13	2. Test phase (function sequence for valve proving valve 2): <ul style="list-style-type: none"> <li>▪ valve 1 opens, valve 2 remains closed</li> <li>▪ pressure between valve 1 and valve 2 increases</li> <li>▪ valve 1 closes again</li> </ul>
14	Test time valve 2.
15	Following the post-purge phase the burner motor switches off. The actuators of the air damper and gas butterfly valve close.
OFF	Standby, no heat demand.

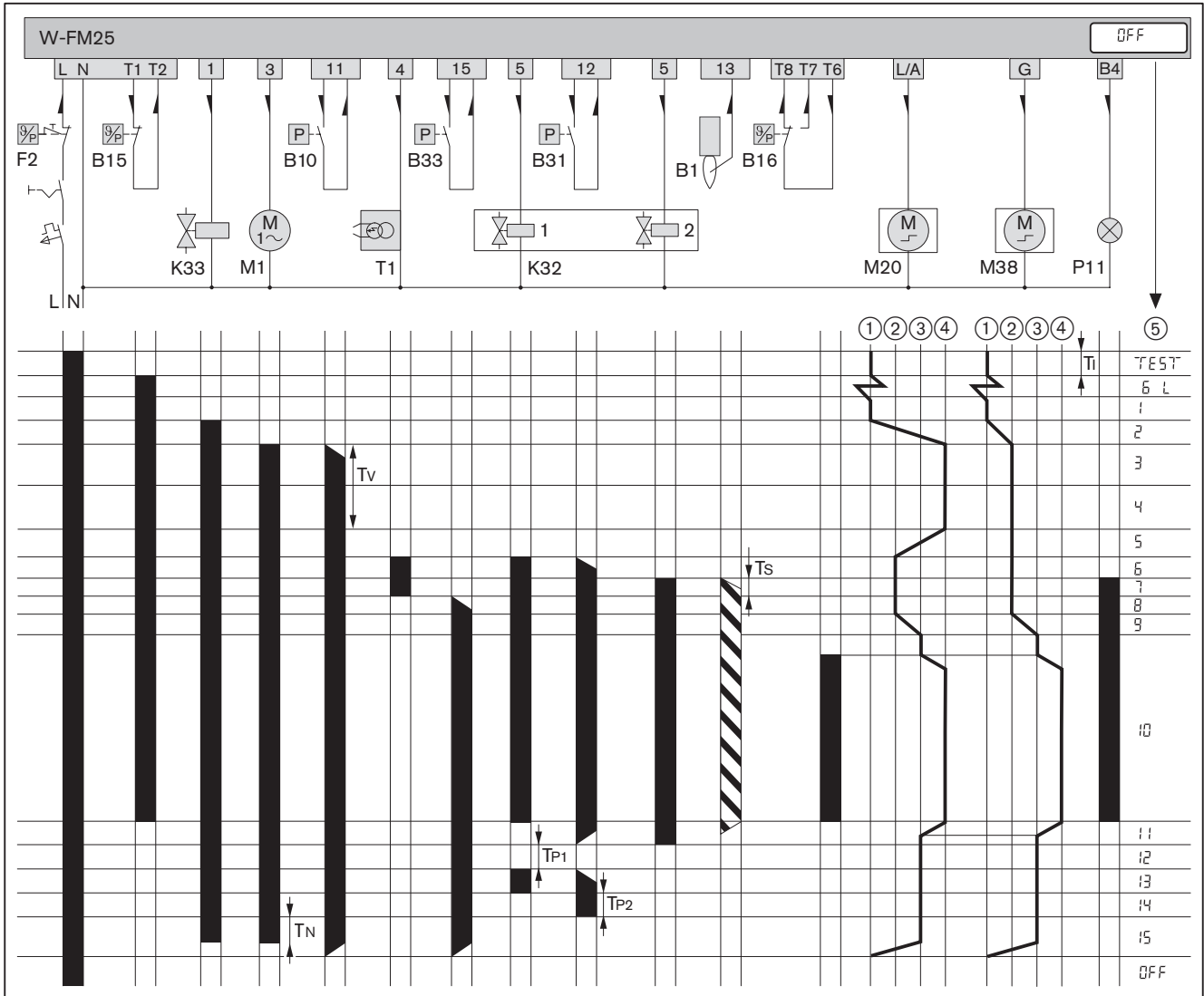

- |     |   |                 |   |
|-----|---|-----------------|---|
| B1  | Ionisation electrode                                      | ①               | CLOSED position                             |
| B10 | Air pressure switch                                       | ②               | Ignition position                           |
| B15 | Temperature or pressure regulator                         | ③               | Partial load                                |
| B16 | Temperature or pressure regulator full load               | ④               | Full load                                   |
| B31 | Low gas pressure switch/valve proving gas pressure switch | ⑤               | Operating phase                             |
| B33 | High gas pressure switch (optional)                       | T <sub>i</sub>  | Initialisation time (Test): 3 s             |
| F2  | Temperature or pressure limiter                           | T <sub>N</sub>  | Post-purge time: 2 s [ch. 6.2.3].           |
| K32 | double gas valve  | TP <sub>1</sub> | 1. Test phase: 8 s (valve proving valve 1)  |
| K33 | External valve LPG  | TP <sub>2</sub> | 2. Test phase: 16 s (valve proving valve 2) |
| M1  | Burner motor  | T <sub>v</sub>  | Pre-purge time: 20 s                        |
| M20 | Air damper actuator                                       | T <sub>s</sub>  | Safety time: 3 s                            |
| M38 | Gas butterfly valve actuator                              |                 | Voltage is applied                          |
| P11 | Control lamp operation (optional)                         |                 | Flame signal present                        |
| T1  | Ignition unit   |                 | Current path                                |

3 Product description

3.3.5 Inputs and outputs

Observe wiring diagram supplied.

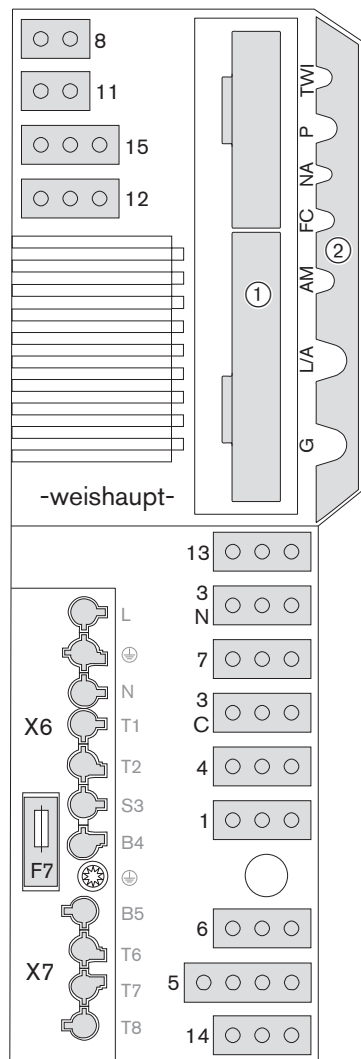

- |     |  |
|-----|--|
| TWI | TWI interface (VisionBox, accessory)                                   |
| P   | O <sub>2</sub> sensor (accessory)                                      |
| NA  | Not used   |
| FC  | Not used   |
| AM  | Operating panel  |
| L/A | Air damper actuator  |
| G   | Gas butterfly valve actuator   |
| ①   | Slot analogue module EM3/3 or Fieldbus module EM3/2                    |
| ②   | W-FM cover   |
| 1   | External valve LPG   |
| 3C  | Burner motor for continuous running fan                                |
| 3N  | Burner motor   |
| 4   | Ignition unit  |
| 5   | Multifunction assembly   |
| 6   | Not used   |
| 7   | Bridging plug No. 7  |
| 8   | Gas meter (impulse generator)  |
| 11  | Air pressure switch / air pressure switch for ducted air intake (LDW2) |
| 12  | Low gas pressure switch/valve proving gas pressure switch              |
| 13  | Ionisation   |
| 14  | Remote reset or low gas pressure switch (optional)                     |
| 15  | Bridging plug No. 15 or high gas pressure switch                       |
| X6  | 7 pole connection plug   |
| X7  | 4 pole connection plug   |
| F7  | Internal unit fuse (T6.3H, IEC 127-2/5)                                |



### 3.4 Technical data

#### 3.4.1 Approval data

PIN (EU) 2016/426	CE-0085BM0216
Basic standards	EN 676:2020 + AC:2022 Additional standards, see EU Declaration of Conformity.

#### 3.4.2 Electrical data

Mains voltage / Mains frequency	230 V/50 Hz
Consumption at start	max 428 W
Consumption during operation	max 328 W
Power consumption	max 2.1 A
Internal unit fuse	T6.3H, IEC 127-2/5
External fuse	max 16 A type B

#### 3.4.3 Ambient conditions

Temperature in operation	-15 ... +40 °C <sup>(1)</sup>
Temperature during transport/storage	-20 ... +70 °C
relative humidity	max 80 %, no dew point
Installation elevation	max 2000 m <sup>(2)</sup>

<sup>(1)</sup> +50 °C with motor W-PM...

<sup>(2)</sup> Consultation with Weishaupt is required for higher installation elevation.

#### 3.4.4 Permissible fuels

- Natural Gas E/LL
- Liquid Petroleum Gas B/P
- Natural gas with hydrogen content > 10 %, see supplementary manual (Print No. 835927xx)

3 Product description

3.4.5 Emissions

Flue gas

- Emission Class 5 for Natural gas to EN 676.
- Emission Class 4 for Liquid Petroleum Gas to EN 676

The NO<sub>x</sub> values are influenced by:

- combustion chamber dimensions
- flue gas system
- Fuel
- combustion air (temperature and humidity)
- medium temperature

Combustion chamber dimensions, see Weishaupt Partner Portal (Documents and Applications → Online Applications → NO<sub>x</sub> calculation for burner).

Sound levels

Dyad noise emission values

Measured sound power level L <sub>WA</sub> (re 1 pW)	78 dB(A) <sup>(1)</sup>
Uncertainty value K <sub>WA</sub>	4 dB(A)
Measured sound pressure level L <sub>pA</sub> (re 20 µPa)	73 dB(A) <sup>(2)</sup>
Uncertainty value K <sub>pA</sub>	4 dB(A)

<sup>(1)</sup> Determined to ISO 9614-2.

<sup>(2)</sup> Determined at 1 metre distance from the front of the burner.

The measured noise levels plus uncertainty values form the upper limit value, which could occur when measuring.

### 3.4.6 Rating

#### Combustion heat rating

Natural Gas	35 ... 200 kW
LPG	35 ... 200 kW

#### Capacity graph

Capacity graph to EN 676.

The capacity data given relates to an installation elevation of 0 m above sea level. For installation elevations above 0 m a capacity reduction of approx. 1 % per 100 m applies.

A limited capacity graph is valid for ducted air intake.

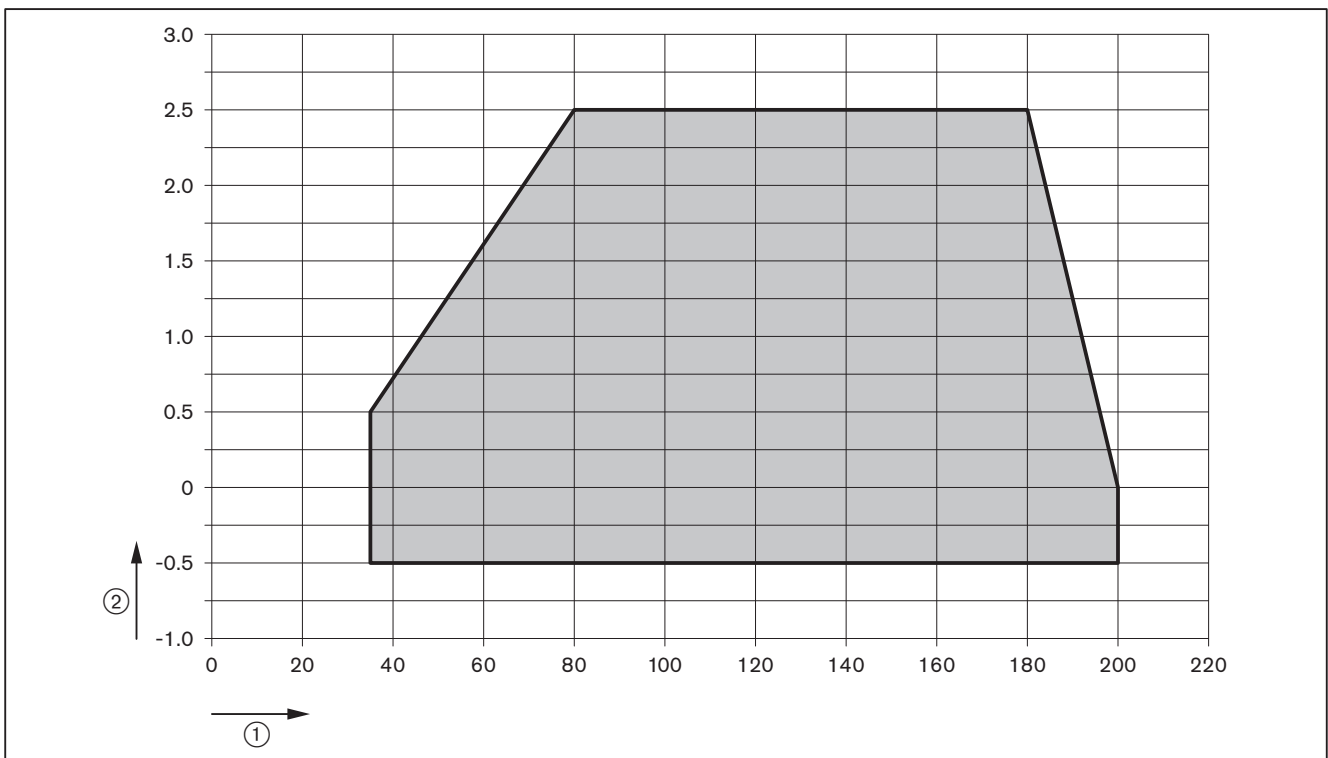

- ① Combustion heat rating [kW]
- ② Combustion chamber pressure [mbar]

3 Product description

3.4.7 Dimensions

Burner

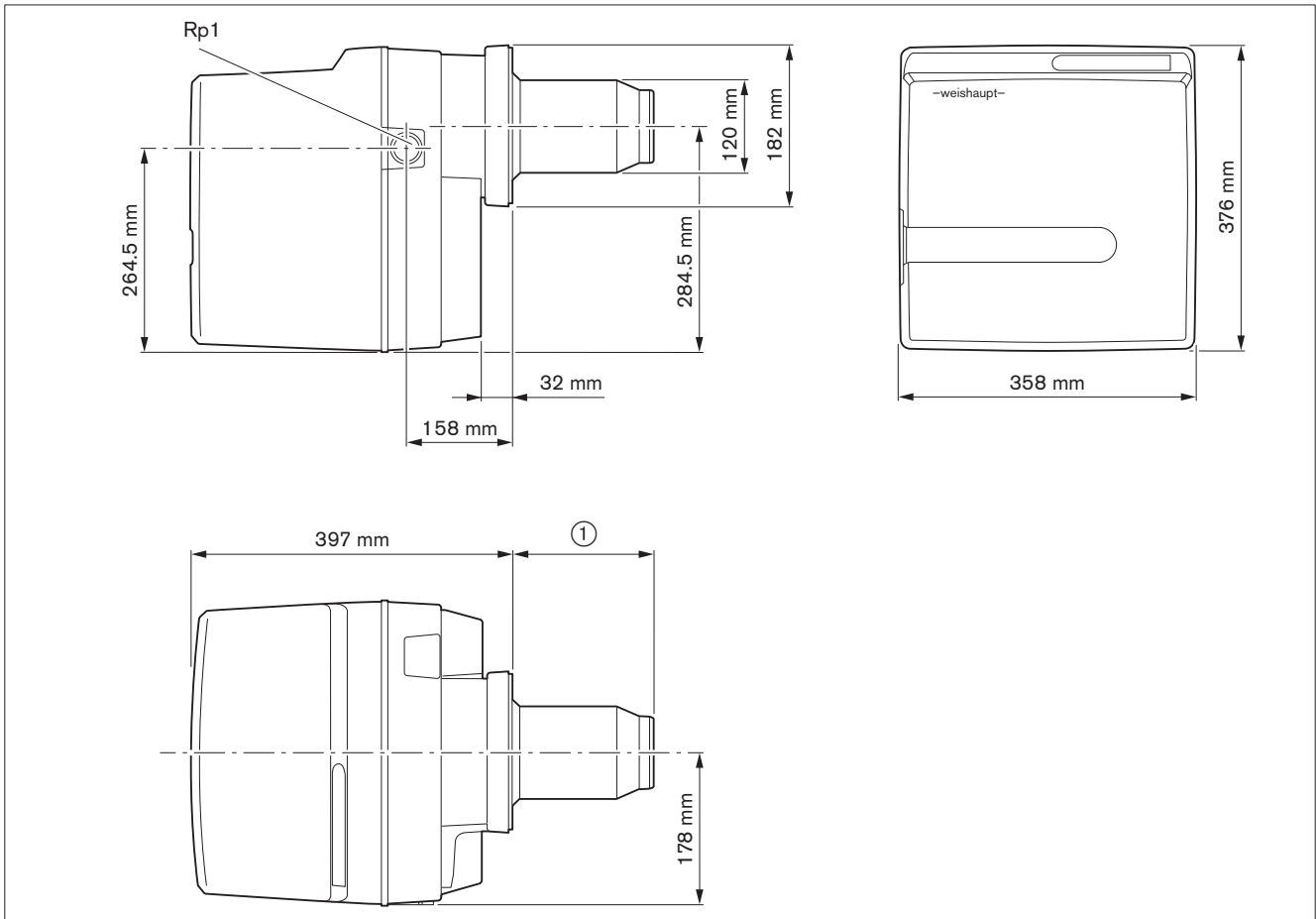

- ① 140 mm without combustion head extension
- 240 mm with combustion head extension (100 mm)
- 340 mm with combustion head extension (200 mm)
- 440 mm with combustion head extension (300 mm)

**Valve train**

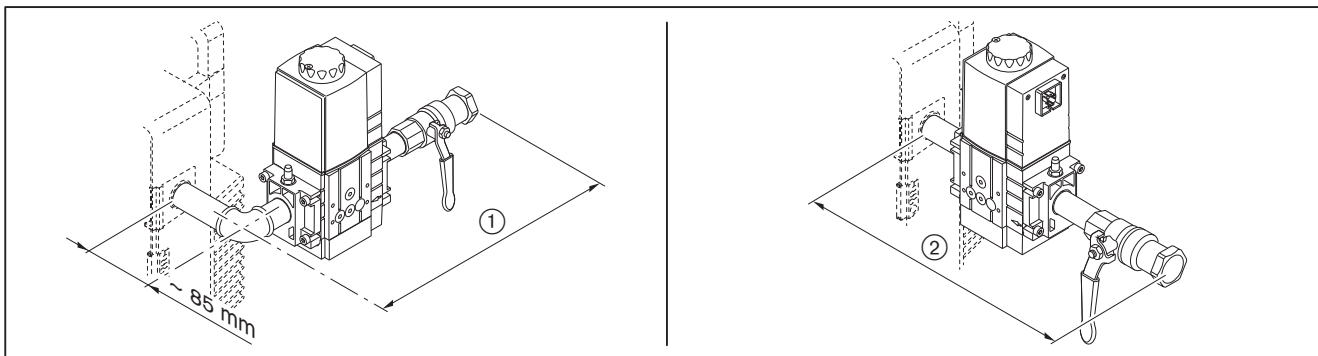

	Valve train	Ball valve	With thermal shut off device	Without thermal shut off device
①	W-MF 507	Rp <sup>3/4</sup>	approx. 315 mm	approx. 300 mm
		Rp1	approx. 320 mm	approx. 305 mm
	W-MF 512	Rp1	approx. 350 mm	approx. 330 mm
②	W-MF 507	Rp <sup>3/4</sup>	approx. 305 mm	approx. 290 mm
		Rp1	approx. 315 mm	approx. 295 mm
	W-MF 512	Rp1	approx. 355 mm	approx. 335 mm

**3.4.8 Weight**

approx. 20 kg

4 Installation

4 Installation

4.1 Installation requirements

**Burner type and capacity graph**

Burner and heat exchanger must be matched.

- ▶ Check burner type and burner capacity.

**Installation location**

- ▶ Prior to installation ensure that:
  - sufficient space is available for normal and service position [ch. 3.4.7]
  - sufficient combustion air is available and, if necessary, a ducted air intake is installed

**Prepare heat exchanger**

The refractory ③ must not protrude beyond the front edge of the combustion head. The refractory can take a conical shape (min 60°).

Refractory may not be required on boilers with water-cooled front, unless the manufacturer gives other instructions.

Following installation, the aperture ④ between flame tube and refractory should be filled with flame-proof, resilient insulating material. Do not make solid.

Heat exchangers with deep refractories or thick doors, or heat exchangers with reverse flame combustion chambers may require a combustion head extension. Head extensions of 100, 200 and 300 mm are available. Dimension ② then changes according to the head extension used.

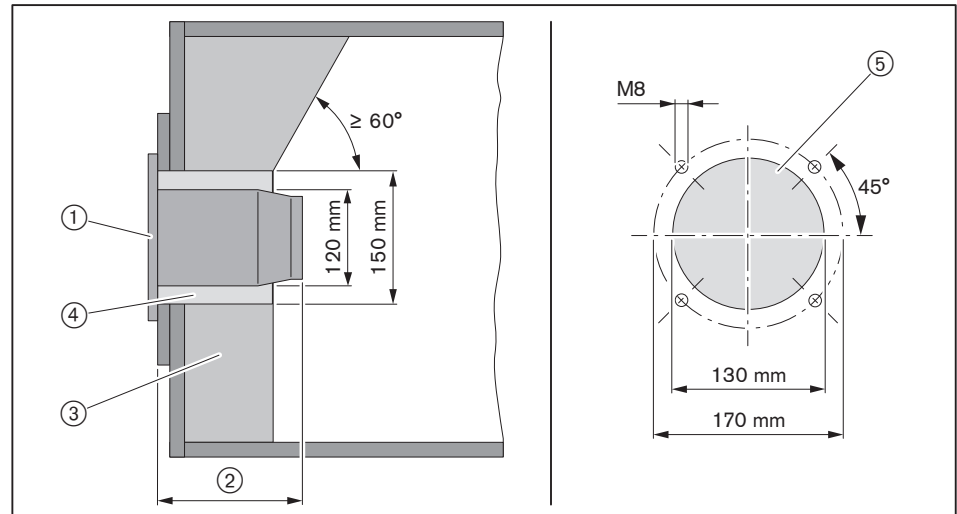

- ① Flange gasket
- ② 140 mm
- ③ Refractory
- ④ Aperture
- ⑤ Boiler plate recess

## 4.2 Burner installation



### Only valid in Switzerland

When installing and operating the regulations of SVGW, of the VKF, local and Cantonal regulations and the EKAS-guideline No. 6517: LPG guideline must be observed.

- ▶ Remove mixing head [ch. 9.3].
- ▶ Remove burner flange ① from burner housing.



The burner in its standard version is designed for valve train connection from the right. For gas valve train connection from the left the burner has to be installed rotated by 180° [ch. 4.2.1]. To do this, additional conversion measures are required [ch. 5.1.1].

- ▶ Fit flange gasket ② and burner flange ① to the heat exchanger using screws ③.
- ▶ The aperture between flame tube and refractory should be filled with flame-proof, resilient insulating material (do not make solid).

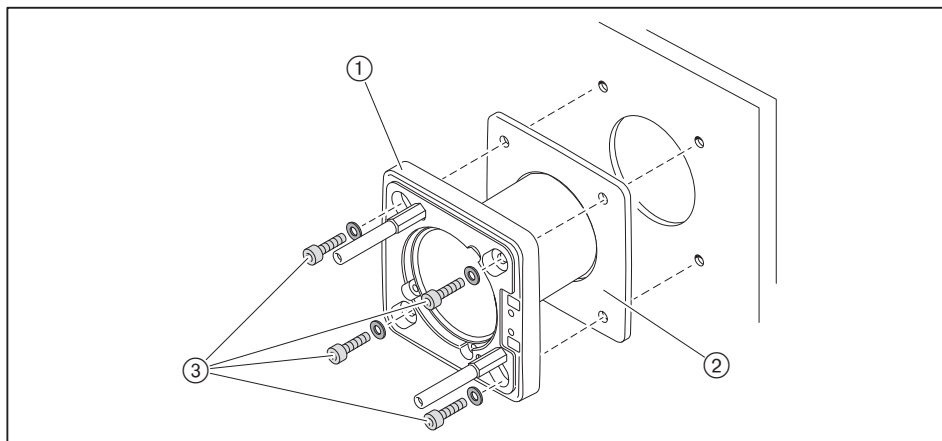

- ▶ Mount burner with screws ① to burner flange.

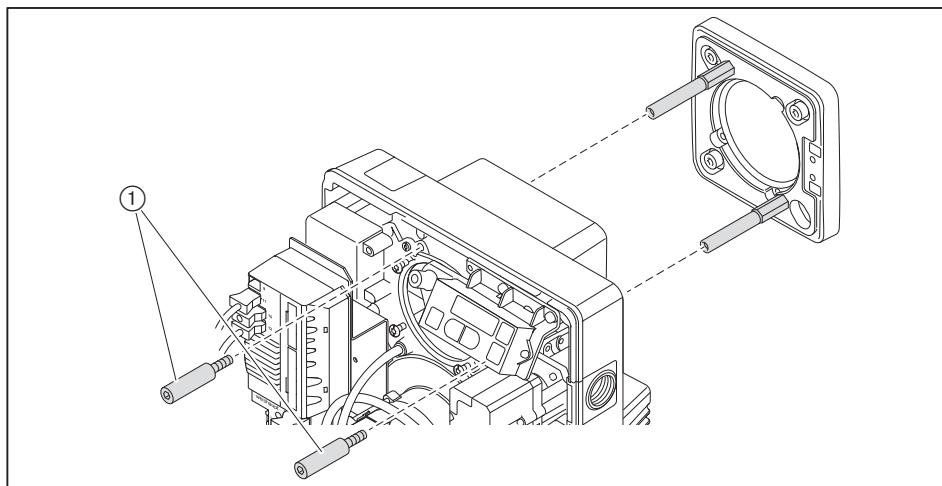

- ▶ Check setting of electrodes [ch. 9.5].
- ▶ Fit mixing head [ch. 9.3].

4 Installation

4.2.1 Rotate burner by 180° (optional)

- ▶ Mount operating panel ① on the opposite side of the housing.
- ▶ Mount fixing bracket ③ on the opposite side of the housing.
- ▶ Move the combustion manager upwards, using the holes (20 mm higher) on the retaining bracket.
- ▶ Rotate burner flange ② 180° and mount with flange gasket.
- ▶ Rotate burner 180° and mount to burner flange securing with screws ④.
- ▶ The aperture between flame tube and refractory should be filled with flame-proof, resilient insulating material (do not make solid).
- ▶ Check setting of electrodes [ch. 9.5].
- ▶ Fit mixing head [ch. 9.3].

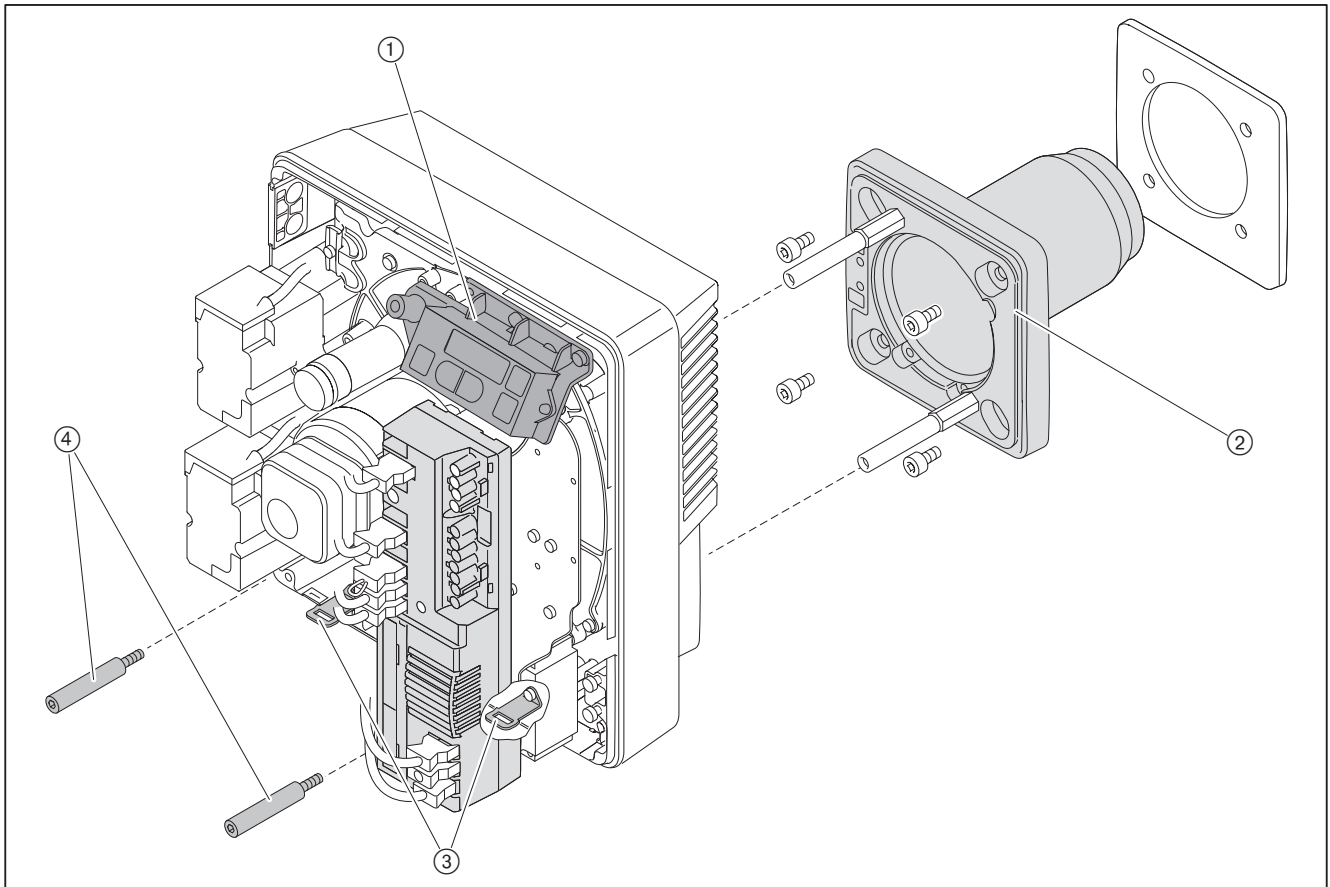



## 5 Installation

### 5.1 Gas supply



#### Risk of explosion due to leaking gas

Gas leaks can lead to a build-up of explosive gas/air mixture. With an ignition source present this can result in an explosion.

- ▶ Install gas supply with care.
- ▶ Observe all safety instructions.

Only a competent installation company may carry out the installation of the gas pipe system, including the gas ball valve upstream of the gas appliance. Observe local regulations.

All work downstream from the gas ball valve may be carried out by a contract installation company or a service-/qualified subcontractor for gas appliances in accordance with DVGW G 676.

Ask the gas supply company to specify the following:

- Type of Gas
- Gas connection pressure
- Calorific value in normal condition [kWh/m<sup>3</sup>]

Observe maximum permissible pressure of all components of the gas valve train.

- ▶ Close all fuel shut off devices prior to commencing work and protect from accidental re-opening.

#### General installation instructions

- Install manually operated shut off device (gas isolation valve) in the supply.
- Ensure correct mounting alignment and cleanliness of sealing surfaces.
- Mount valve train free of vibration. It must not be allowed to swing. Suitable supports should be fitted.
- Mount gas valve train free of stresses.
- The distance between burner and Multifunction assembly should be as small as possible. If the distance is too great, it is possible that a gas/air mixture is formed, which will influence burner start.
- Observe sequence and flow direction of gas valve train.
- If necessary, fit thermal shut off device (TAE) in front of the gas isolation valve.

#### Installation position

Multifunction assembly can be installed with the axis standing vertical to lying horizontal.

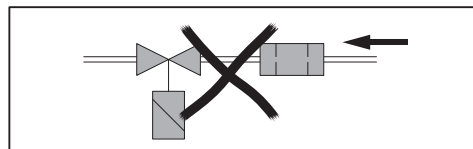

5 Installation

5.1.1 Installing the gas valve train



**Only in conjunction with W-MF and gas connection pressure > 150 mbar**  
If the gas connection pressure is > 150 mbar, a pressure regulator has to be fitted upstream of the W-MF.  
▶ Install the gas valve train, see additional sheet (Print No. 835109xx).

**Installing the valve train from the right**

- ▶ Remove protective film and closing plug.
- ▶ Mount gas valve train free of stresses. Do not compensate for installation errors by over-tightening the flange screws.
- ▶ Ensure correct alignment of flange seals.
- ▶ Tighten screws evenly diagonally across.



No additional sealant is required if the thread is coated in blue.

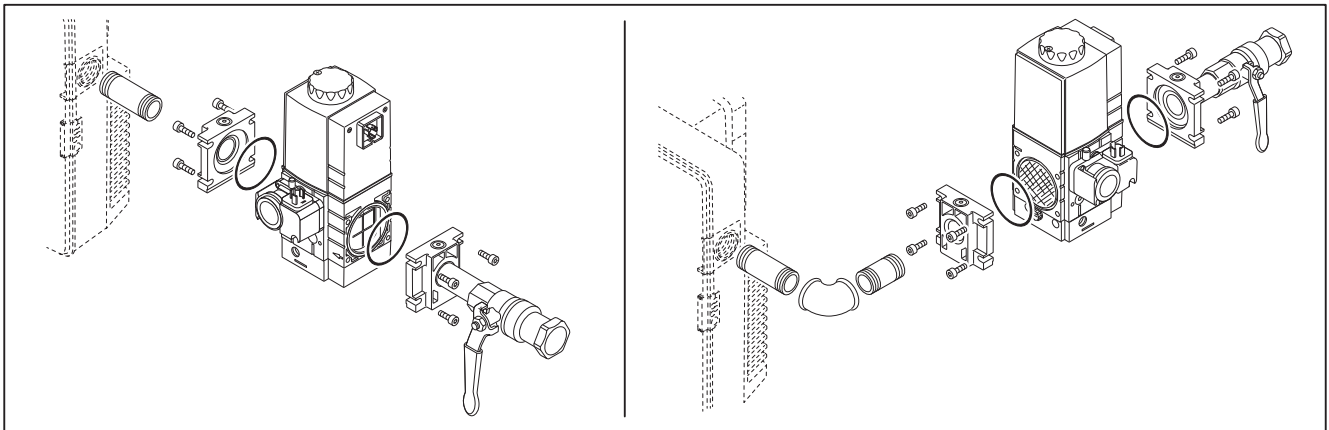

### Installing the gas valve train from the left

To fit the gas valve train to the burner from the left, the burner has to be installed rotated by 180°. To do this, additional conversion measures are required.

Move the gas pressure switch prior to installing the multifunction assembly:

- ▶ Remove closing plug ① and gas pressure switch ③.
- ▶ Mount gas pressure switch ③ and O ring ② on the opposite side.
- ▶ Mount closing plug ① on the opposite side.

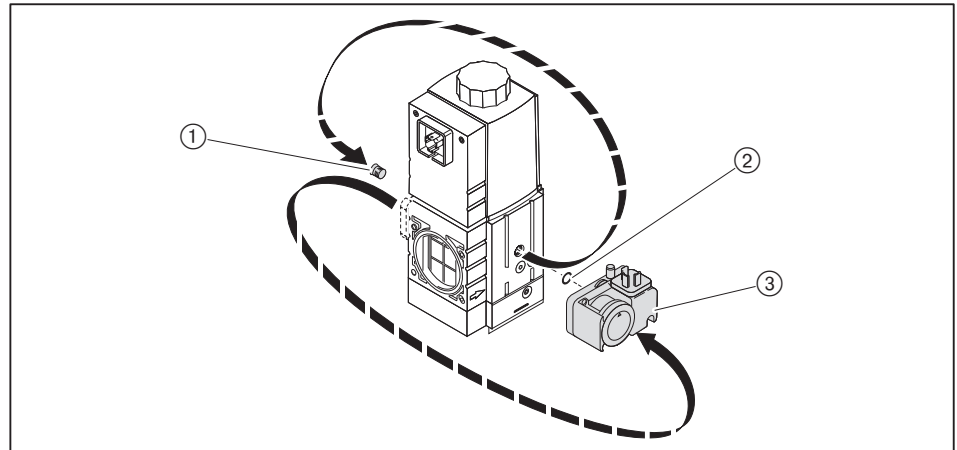

- ▶ Continue installation in the same way as for "Mount gas valve train from the right".

### Accessories

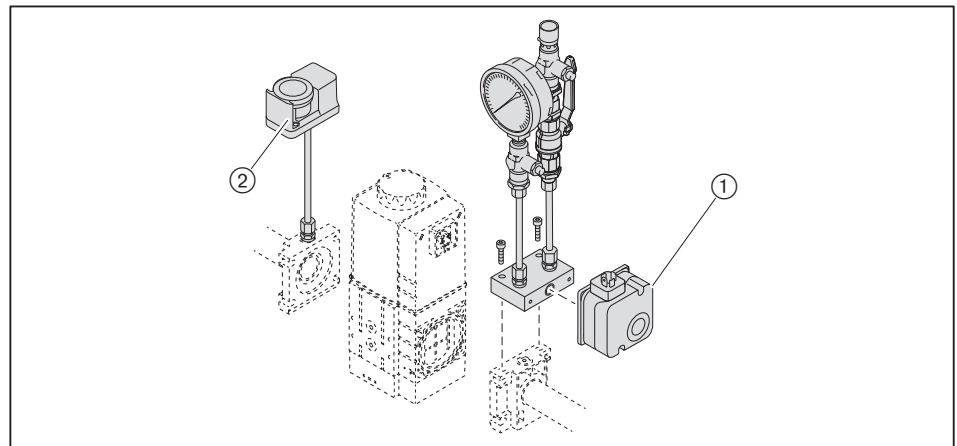

- ① Low gas pressure switch with mechanical interlock (B34)
- ② High gas pressure switch (B33)

## 5 Installation

### 5.1.2 Carry out soundness test of gas supply line and vent

Only a competent installation company may carry out the soundness test and vent the gas pipe system.

## 5.2 Electrical connection



### Risk of electric shock

Working on the device when voltage is applied can lead to electric shock.

- ▶ Isolate the device from the power supply prior to starting any work.
- ▶ Safeguard against accidental restart.

The electrical connection must only be carried out by qualified electricians. Observe local regulations.

Observe wiring diagram supplied.

- ▶ Plug in plug for gas pressure switch ② and double gas valve ③ and secure with screws.
- ▶ Check polarity and wiring of 7 pole connection plug ①.
- ▶ Plug in connection plug ①.
- ▶ Check polarity and wiring of 4 pole connection plug ④.
- ▶ Plug in connection plug ④.

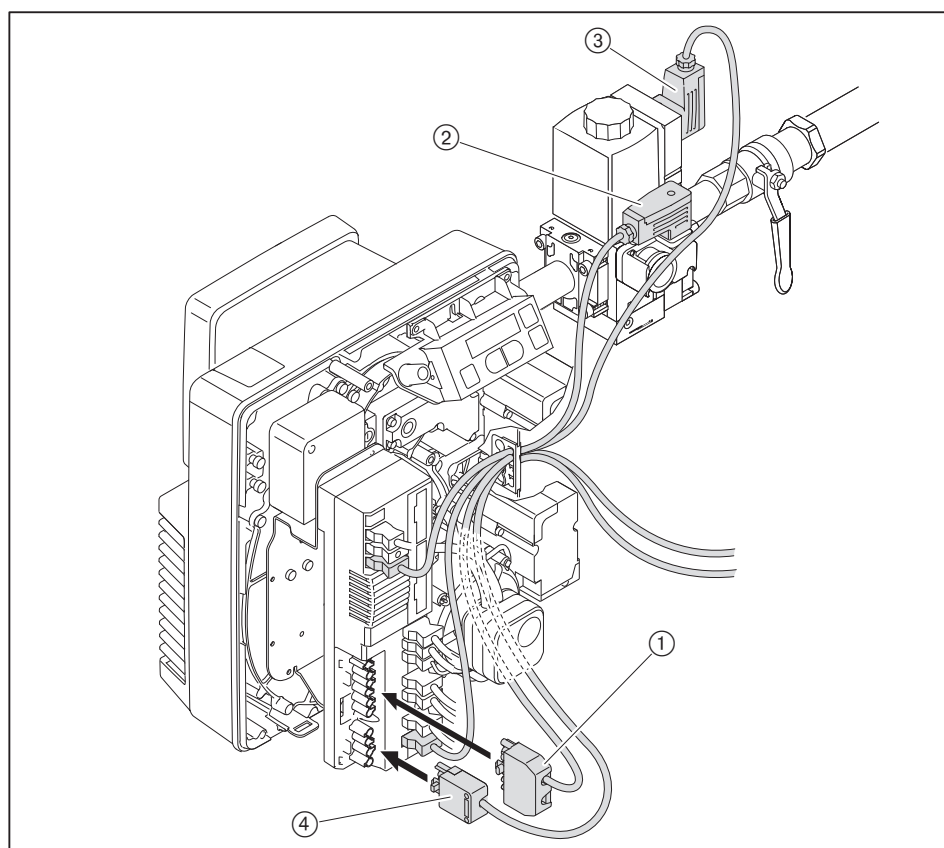

With remote reset, do not exceed maximum cable length of 50 metres.

6 Operation

6 Operation

6.1 Operating panel

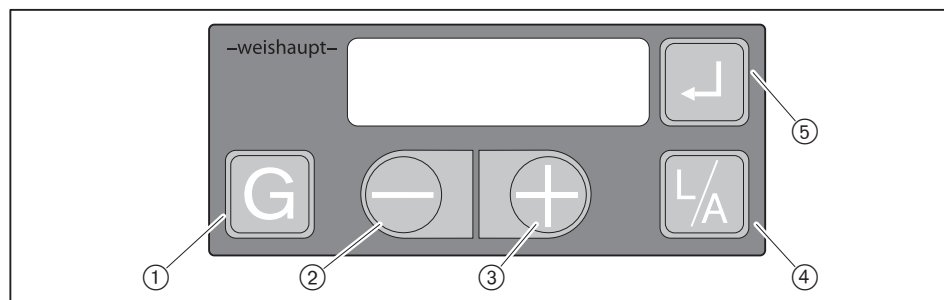

①	[G] Gas	Select gas butterfly valve actuator
②	[-]	Change values
③	[+]	
④	[L/A] Air	Select air damper actuator
⑤	[Enter]	<ul style="list-style-type: none"> <li>▪ Reset burner</li> <li>▪ Call up information:                             <ul style="list-style-type: none"> <li>- press for approx. 0.5 seconds: Info level</li> <li>- press for approx. 2 seconds: Service level</li> </ul> </li> </ul>
③ and ⑤	[+] and [ENTER]	press simultaneously for approx. 2 seconds: Parameter level (only possible with display OFF)



Various actions are only triggered when the key is released, for example changing the display, reset.

**OFF function**

- ▶ Press [ENTER], [L/A] and [G] keys simultaneously.
- ✓ Immediate lockout with error 18h.

**Operating level**

The current actuator position can be displayed in the operating level (10).

Displaying gas butterfly valve setting:

- ▶ Press key [G].

Displaying air damper setting:

- ▶ Press key [L/A].

**Flame signal**

The flame signal can be displayed during commissioning (setting level) by using a combination of keys.

- ▶ Press [Enter], [L/A] and [G] keys simultaneously.
- ✓ The flame signal is displayed.

Recommended flame signal, see Service level information 19 [ch. 6.2.2].

### Operating status

The exact operating status of the combustion manager can also be displayed. This simplifies determining the cause of a fault during troubleshooting [ch. 11.1].

- ▶ Press and hold [-] and [+] simultaneously for approx. 3 seconds.
- ✓ The combustion manager changes to operating display. The display shows current operating status with a number.

Back to standard display:

- ▶ Press and hold [-] and [+] simultaneously for approx. 3 seconds.

### VisionBox Software (optional)

If the VisionBox Software is connected, change-over to the access level must be confirmed via the operating panel.

- ▶ Press [+]
- ✓ Software changes to the access level

6 Operation

6.2 Display

The display shows the current operating status and operating data.

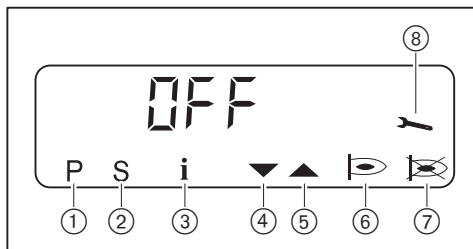

- ① Setting level activated
- ② Start phase activated
- ③ Info level activated
- ④ Actuator runs CLOSED
- ⑤ Actuator runs OPEN
- ⑥ Burner in operation
- ⑦ Lockout
- ⑧ Service level activated

7 E57

Combustion manager performs self test [ch. 3.3.4]

OFF

Standby, no heat demand

OFF S

Shutdown via contact X3:7 (plug No. 7)

OFFUPr

Unprogrammed condition or programming not completed

OFF E

Standby, no heat demand, shutdown via fieldbus module

OFF6d

Insufficient gas low gas pressure switch

10

Current operating phase [ch. 3.3.4]

F1

Under-voltage in Standby  
or internal device error, see error memory

F9

Connection to Fieldbus faulty  
Acknowledge error: press [-] and [+] keys simultaneously.



### 6.2.1 Info level

Burner data can be interrogated in the Info level .

- ▶ Press [Enter] for approx. 0.5 seconds.
- ✓ The Info level is activated.
- ▶ Press [Enter] to reach the next information.

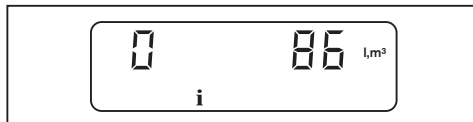

No.	Information
0	Total gas consumption in m <sup>3</sup> (via X3:8) Reset value: ▶ Press [L/A] and [+] simultaneously for approx. 2 seconds.
1	Hours run
2	- no function -
3	Burner starts
4	Device item number
5	Index of device item number
6	Device number
7	Production date (DDMMYY)
8	Fieldbus address
9	Valve proving behaviour
11	Not used
12	Current gas consumption (0.1 m <sup>3</sup> /h)
13	Analogue module EM3/3 or Fieldbus module EM3/2 available 0: no 1: yes

After information 13 or a waiting time of approx. 20 seconds the combustion manager changes over to the operating level.

6 Operation

6.2.2 Service level

The service level provides information about:

- actuator position of the individual operating points
  - the most recent fault
  - flame signal during burner operation
- ▶ Press [Enter] for approx. 2 seconds.  
 ✓ The service level is activated.  
 ▶ Press [Enter] to reach the next information.

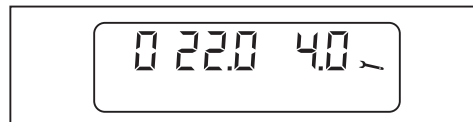

No.	Information
0	Actuator position in operating point P0
1	Actuator position in operating point P1
2	Actuator position in operating point P2
3	Actuator position in operating point P3
4	Actuator position in operating point P4
5	Actuator position in operating point P5
6	Actuator position in operating point P6
7	Actuator position in operating point P7
8	Actuator position in operating point P8
9	Actuator position in operating point P9
10 ... 18	Fault memory most recent fault ... ninth last occurred fault Display additional information: 1. detailed error codes / operating status: ▶ Press [+] key. 2. detailed error codes: ▶ Press [-] and [+] keys simultaneously. Repetition counter: ▶ Press key [G].
19	Flame signal Range: 00 ... 58 ▪ < 50: poor quality ▪ 50 ... 58: high quality recommended value: > 50

After information 19 or a waiting time of approx. 20 seconds the combustion manager changes over to the operating level.

### 6.2.3 Parameter level

Settings at parameter level must only be carried out by qualified personnel.

The parameter level can only be called up in Standby (OFF) mode.

- ▶ Press [+] and [Enter] keys simultaneously for approx. 2 seconds.
- ✓ The parameter level is activated.



- ▶ Press [+] key.
- ▶ Press [Enter] to reach the next parameter.
- ✓ Only then will the value be stored.

Pno.	Parameters	Setting range	Factory setting
1	Fieldbus address	0 ... 254 / OFF Switch over to OFF and address: ▶ Briefly press [-] and [+] simultaneously.	OFF
2	Actuator position in Standby	0.0 ... 90.0° Change air damper setting: ▶ Press [L/A] and [+] or [-]. Change gas butterfly valve setting: ▶ Press [G] and [+] or [-].	0.0
3	Function fieldbus module -or- function analogue module	The parameter is dependent on the module used. Setting range of parameters, see installation and operating manual of module. Fieldbus module (response to heat demand): 2: Bus default and control circuit (T1/T2) activated Analogue module: 2: DIP switches activated	2
4	Post-purge time	0 ... 4095 s	2
5	Fault memory	0: fault memory is empty 1: fault memory contains data Delete fault memory: ▶ Press [L/A] and [+] simultaneously for approx. 2 seconds.	-
6	Factor for gas consumption Impulse rate of meter per m <sup>3</sup>	1 ... 65535 200 impulses ± 1 m <sup>3</sup> ▶ Adjust factor depending on impulse rate of gas meter.	200
A	Low gas pressure switch/valve proving gas pressure switch (X3:12)	0: not activated 1: Proof-of-closure (valve 1) 2: without low gas pressure switch 3: with low gas pressure switch	3
b	Air pressure switch (X3:11) (display only, no adjustment possible)	0: not activated 1: activated	1
C	Operating mode output X3:1	0: not activated 1: with pilot valve not interrupted 2: with pilot valve interrupted 3: Standard (external LPG valve)	3

6 Operation

Pno.	Parameters	Setting range	Factory setting
d	Flame sensor	0: ionisation electrode or flame sensor FLW 1: switch input (X3:14) 2: flame sensor QRB4 or flame sensor for continuous operation	0
E	Display mode	0: E-parameter is not activated in the access level 1: E-parameter is activated in the access level  Settings 2 and 3 are required for O <sub>2</sub> trim, see supplementary sheet "O <sub>2</sub> trim W burners" (Print No. 835587xx).	0
F	Restart attempts following flame failure	0 ... 1	1
H	Actuator setting for post-purge	0.0 ... 90.0°  Change air damper setting: ▶ Press [L/A] and [+] or [-].	20.0
L	Load shutdown	0.0 ... 4095 seconds  If there is no longer a demand for heat, the W-FM reduces the burner capacity and closes the fuel valves after the time set has elapsed. If partial load is reached before the time has elapsed, the fuel valves close immediately.	0
n	Operating mode O <sub>2</sub> trim (only in conjunction with O <sub>2</sub> trim)	0: not activated  Additional parameters can be displayed with setting 1 ... 4, see supplementary sheet "O <sub>2</sub> trim W burners" (Print No. 835587xx).	0

After the last parameter or a waiting time of approx. 20 seconds the combustion manager changes over to the operating level.

### 6.2.4 Access level

Settings at access level must only be carried out by qualified personnel.

The configuration can be adapted relative to the burner type and/or version in the access level.

In the parameter level, the display mode must be configured to 1, to enable access to parameters E0 ... E3 [ch. 6.2.3].

- ▶ Press [G] and [L/A] simultaneously.
- ✓ The access level is activated.



- ▶ Press [+] key.
- ✓ Parameter E0 is displayed.
- ▶ Press and hold [Enter] key and set the parameter using [+] or [-].
- ▶ Press [+] to reach the next parameter.

Parameters	Information	Setting range
E0	Burner type	0: single fuel burner 1: dual fuel burner
E1	Operating mode (display only, no adjustment possible)	0: intermittent operation 1: continuous operation
E2	Flame sensor type	0: ionisation electrode or flame sensor KLC 1: switch input (X3:14) 2: flame sensor QRB4 or flame sensor for continuous operation
E3	Fan configuration	0: Off 1: fan control 2: fan control with fan monitoring 3: VSD 4: fan control according to modulating degree specified 5: DAU control 6 ... 255: off

## 6 Operation

### 6.3 Linearisation

During commissioning it is possible to carry out linearisation of the operating points in gas operation.

During linearisation a straight line is generated from the operating point displayed to P9. The values on the straight are adopted as the new operating points.

#### Initiate a calculation after P9

- ▶ Press [Enter].
- ✓ Combustion manager changes to linearisation mode.

The linearisation mode can be interrupted using the [-] key.

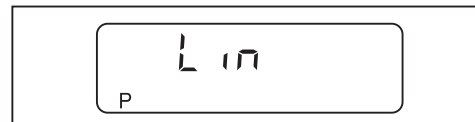

- ▶ Confirm with [+] key.
- ✓ Linearisation is initiated.



#### Example:

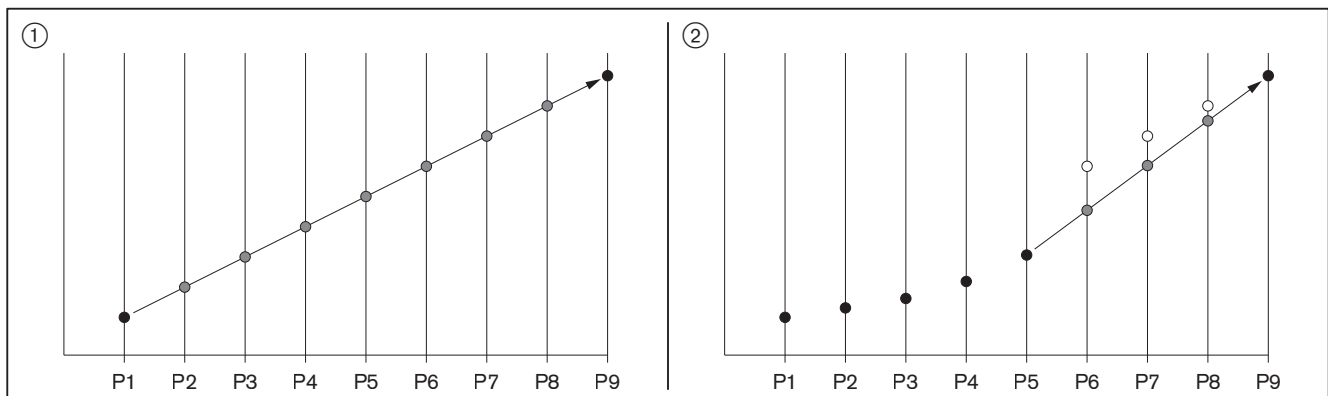

- ① Calculation from P1 to P9
- ② Calculation from P5 to P9

## 7 Commissioning

### 7.1 Prerequisite

Commissioning must only be carried out by qualified personnel.

Only correctly carried out commissioning ensures the operational safety.



Do not operate the burner outside of the capacity graph [ch. 3.4.6].

- ▶ Prior to commissioning ensure that:
  - all assembly and installation work has been carried out correctly
  - sufficient combustion air is available and, if necessary, a ducted air intake is installed
  - the annulus between flame tube and heat exchanger is filled
  - the heat exchanger is filled with medium
  - the regulating, control and safety devices are functioning and set correctly
  - the flue gas ducts are unimpeded
  - a measuring point conforming to standards is available to measure the flue gas
  - the heat exchanger and flue gas ducting up to the test point are sound, as extraneous air influences the test results
  - the operating instructions of the heat exchanger are complied with
  - a heat demand is available

Additional system-related tests could be necessary. Please observe the operating guidelines for the individual components.

On installations with process equipment, the conditions for safe operation and commissioning must be met, see worksheet 8-1 (Print No. 831880xx).

7 Commissioning

7.1.1 Connect measuring devices

Measuring device for ionisation current

- ▶ Remove ionisation cable from the plug coupling.
- ▶ Connect ammeter in series.

Ionisation current

Extraneous light detection from	1 $\mu$ A
Minimum ionisation current	5 $\mu$ A
Recommended ionisation current	9 ... 15 $\mu$ A

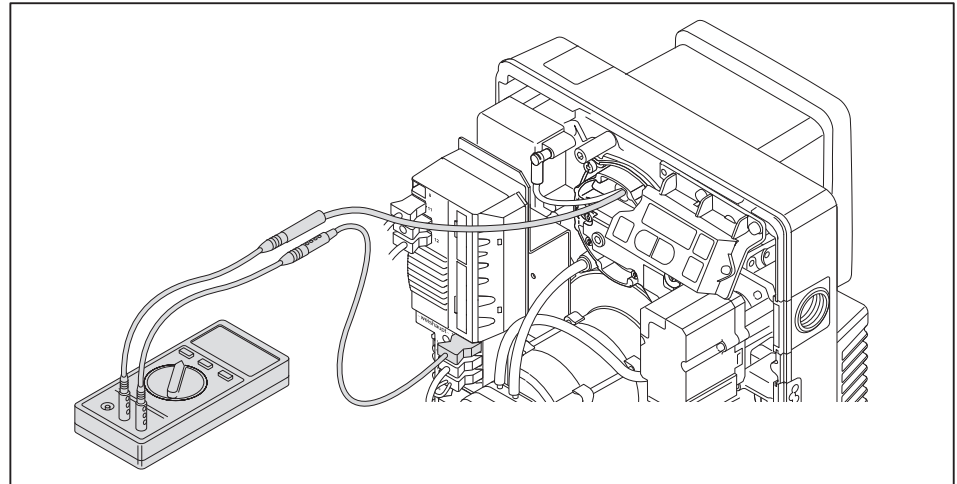

Pressure measuring device for mixing pressure

- ▶ Open test point for mixing pressure ① and connect pressure measuring device.

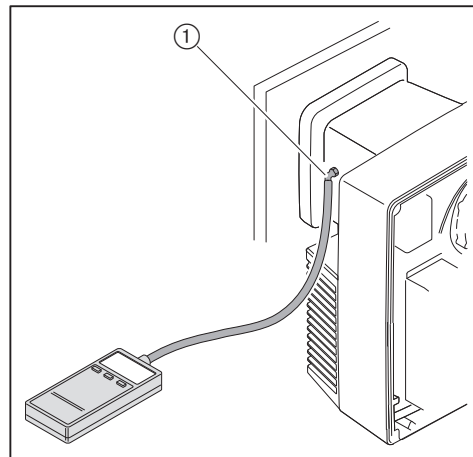



## 7.1.2 Check gas connection pressure

### Minimum connection pressure



Add the combustion chamber pressure in mbar to the minimum connection pressure. The connection pressure should not fall below 15 mbar.

- ▶ Determine minimum connection pressure for low pressure installations from table [ch. 7.1.5].

### Maximum connection pressure

Maximum connection pressure into isolation valve is 300 mbar.

### Check connection pressure



#### Risk of explosion due to excess gas supply pressure

Exceeding the maximum connection pressure (see name plate) can damage the gas valve train and lead to an explosion.

Max. connection pressure see name plate.

- ▶ Check gas connection pressure



#### Only in conjunction with W-MF and gas connection pressure > 150 mbar

The pressure measuring device must be connected to the pressure regulator.

- ▶ Check gas connection pressure, see additional sheet (Print No. 835109xx).

- ▶ Connect pressure measuring device to test point ①.
- ▶ Slowly open isolation valve whilst observing the pressure increase.

If the connection pressure exceeds the max. connection pressure:

- ▶ Immediately close isolation valve.
- ▶ Do not start plant.
- ▶ Notify system operator.

If the connection pressure does not maintain the min. connection pressure:

- ▶ Do not start plant.
- ▶ Notify system operator.

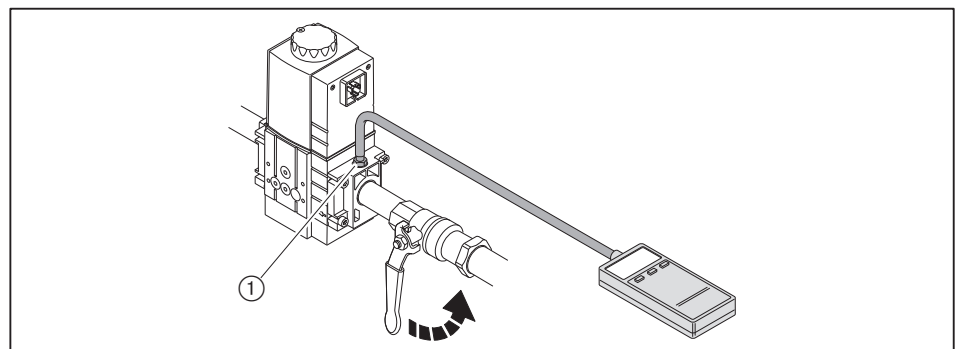

7 Commissioning

7.1.3 Check soundness of gas valve train

Carry out soundness test:

- prior to commissioning
- after all service and maintenance work

	First test phase	Second and third test phase
Test pressure	100 mbar ±10 %	100 mbar ±10 %
Waiting time for pressure equalisation	5 minutes	5 minutes
Test time	5 minutes	5 minutes
Permissible pressure loss	1 mbar	5 mbar

First test phase



**Only in conjunction with W-MF and gas connection pressure > 150 mbar**

In the first test phase, the testing device must be connected to the pressure regulator.

- ▶ Check soundness of gas valve train, see additional sheet (Print No. 835109xx).

In the first phase the valve train section from the gas isolation valve up to the first valve of the multifunction assembly is tested.

- ▶ Switch off burner.
- ▶ Close gas isolation valve.
- ▶ Connect test equipment.
- ▶ Open test point between valve 1 and valve 2.
- ▶ Carry out test to table.

Second test phase

In the second phase the interspace in the multifunction assembly is tested.

- ▶ Connect test equipment.
- ▶ Carry out test to table.

**Third test phase**

In the third phase the valve train section from the multifunction assembly up to the gas butterfly valve is tested.

- ▶ Remove mixing head [ch. 9.3].
- ▶ Fit blanking plate (4).
- ▶ Fit mixing head.
- ▶ Connect test equipment.
- ▶ Carry out test to table.
- ▶ Close all test points.
- ▶ Remove blanking plate.

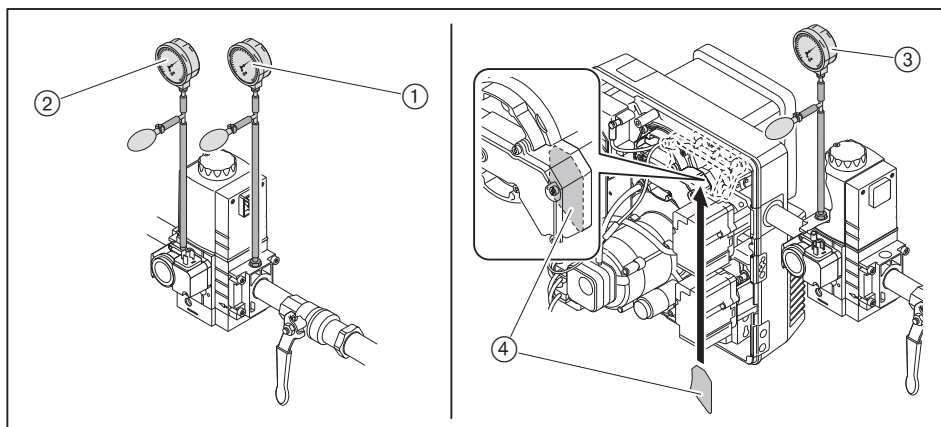

- ① First test phase
- ② Second test phase
- ③ Third test phase
- ④ Blanking plate

7 Commissioning

**Fourth test phase**

In the fourth test phase, the joint to the mixing head ① is tested for soundness. The test phase can only be carried out during or after burner commissioning. A leak detecting spray or electronic gas detector should be used for testing.

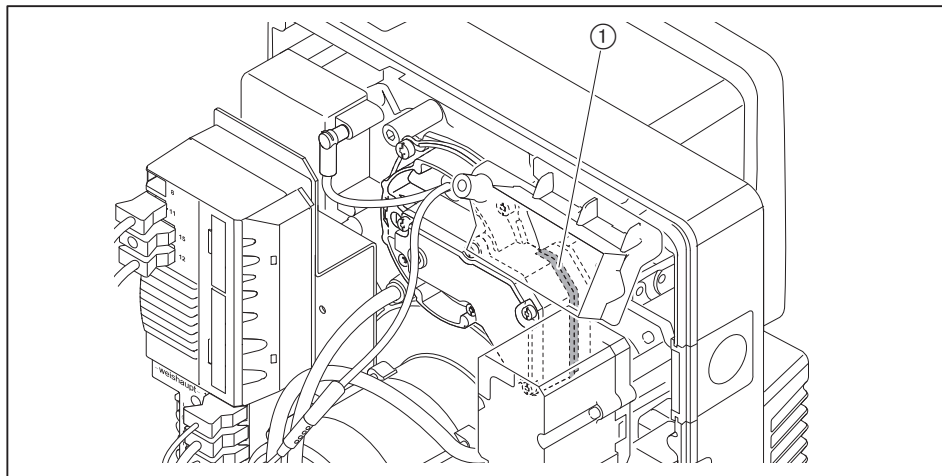

Use only leak detecting foam solutions, which do not cause corrosion, see DVGW-TRGI, worksheet G 600.

- ▶ Check all components, intersections and test points of the gas valve train between multifunction assembly and burner.
- ▶ Document result of the soundness test on the engineer's report.

**Test points**

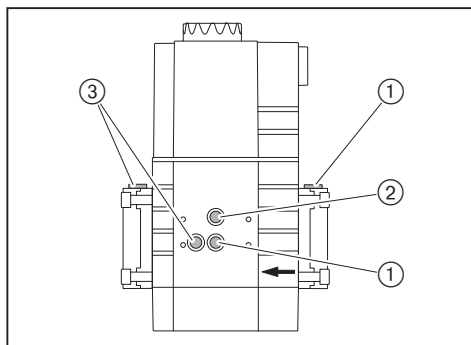

- ① Pressure into valve 1
- ② Pressure between valve 1 and valve 2
- ③ Pressure after valve 2

### 7.1.4 Purging the gas valve train

- ▶ Open test point into valve 1 [ch. 7.1.3].
- ▶ Connect an approved vent hose to the test point.
- ▶ Vent hose must lead to atmosphere.
- ▶ Slowly open gas isolation valve.
- ✓ The gas/air mixture in the valve train vents via the hose to safe atmosphere.
- ▶ Close gas isolation valve.
- ▶ Remove vent hose and immediately close test point.
- ▶ Use a test burner to ensure no air is present in the valve train.

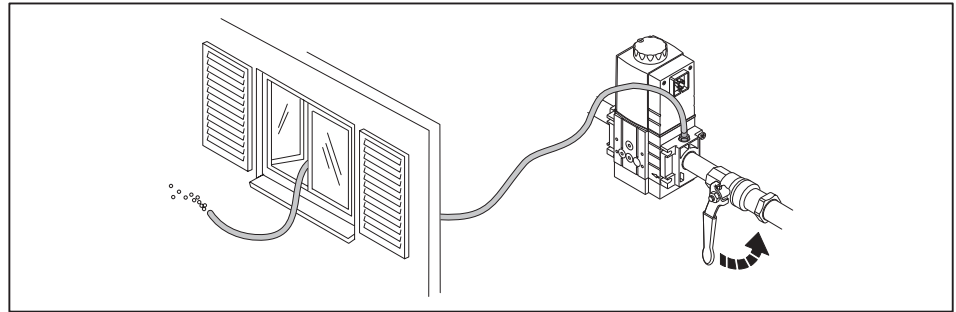

### 7.1.5 Preset pressure regulator

#### Determine setting pressure



Add the combustion chamber pressure in mbar to the setting pressure into the gas butterfly valve.

► Determine setting pressure from the table and note down.

The details given for calorific value  $H_i$  relate to 0 °C and 1013 mbar.

The table values have been calculated under ideal conditions. The values are therefore guide values for basic settings.

Full load [kW]	Setting pressure into gas butterfly valve [mbar]	Min. connection pressure into isolation valve [mbar] (low pressure supply)		
----------------	--	--	--	--

Nominal diameter valve train	¾"	1"	1"
Multifunction assembly W-MF SE	507	507	512

Natural Gas E:  $H_i = 10.35 \text{ kWh/m}^3$ ,  $d = 0.606$

80	8.5	14	13	11
90	8.5	14	13	11
100	8.5	14	13	11
110	8.5	15	14	12
120	8.5	15	14	13
130	8.9	17	15	13
140	9.3	17	15	13
150	9.6	18	16	14
160	9.8	18	16	15
170	10.1	19	16	15
180	10.3	19	16	15
190	10.6	20	17	16
200	10.9	22	18	16

Natural Gas LL:  $H_i = 8.83 \text{ kWh/m}^3$ ,  $d = 0.641$

80	11.0	16	15	13
90	11.0	16	15	13
100	11.0	16	15	14
110	11.0	18	16	14
120	11.0	18	16	15
130	11.4	19	17	16
140	11.7	21	18	16
150	12.2	21	18	17
160	12.7	22	19	17
170	13.2	24	20	18
180	13.6	25	21	18
190	14.0	27	22	19
200	14.4	28	23	20

Full load [kW]	Setting pressure into gas butterfly valve [mbar]	Min. connection pressure into isolation valve [mbar] (low pressure supply)		
		3/4"	1"	1"
Nominal diameter valve train		3/4"	1"	1"
Multifunction assembly W-MF SE		507	507	512
Liquid Petroleum Gas: $H_i = 25.89 \text{ kWh/m}^3$ , $d = 1.555$ The selection is calculated for Propane, it can however, also be used for Butane.				
80	9.3	13	-	-
90	9.3	13	-	-
100	9.3	13	-	-
110	9.3	14	-	-
120	9.3	14	-	-
130	9.6	14	-	-
140	9.9	14	-	-
150	10.2	15	-	-
160	10.4	15	-	-
170	10.7	16	-	-
180	11.0	17	-	-
190	11.9	18	-	-
200	12.8	19	-	-

**Preset setting pressure**



**Only in conjunction with W-MF and gas connection pressure > 150 mbar**  
The pre-pressure must be set to approx. 90 mbar.

► Set FRS pressure regulator, see additional sheet (Print No. 835109xx).

► Preset setting pressure determined at multifunction assembly.

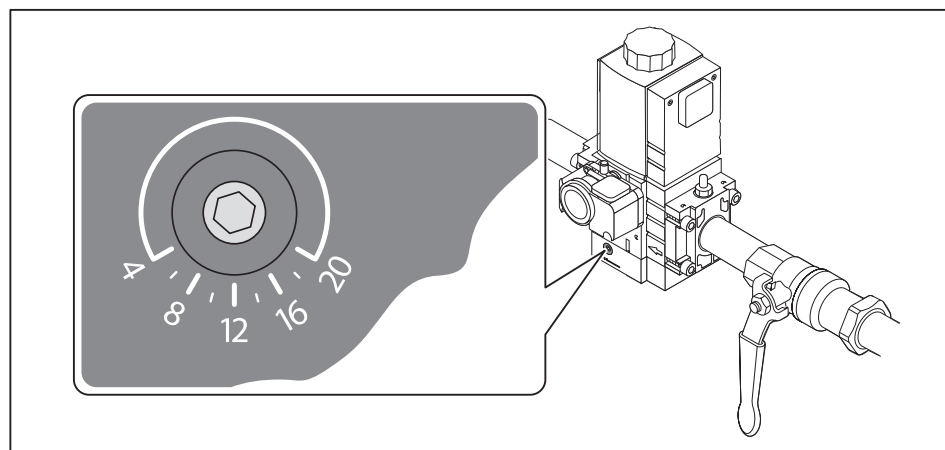

7 Commissioning

7.1.6 Setting values

Set mixing head relative to the combustion heat rating required. For this, the diffuser setting and the air damper setting should be matched.

Determine diffuser and air damper settings



Do not operate the burner outside of the capacity graph [ch. 3.4.6].

► Determine the diffuser setting (dimension X) and air damper setting required from the diagram and note down.

Example

	Example 1	Example 2
Burner capacity required	90 kW	150 kW
Combustion chamber pressure	0.8 mbar	1.3 mbar
Diffuser setting (dimension X)	0 mm	5.5 mm
Air damper setting	43°	> 80°

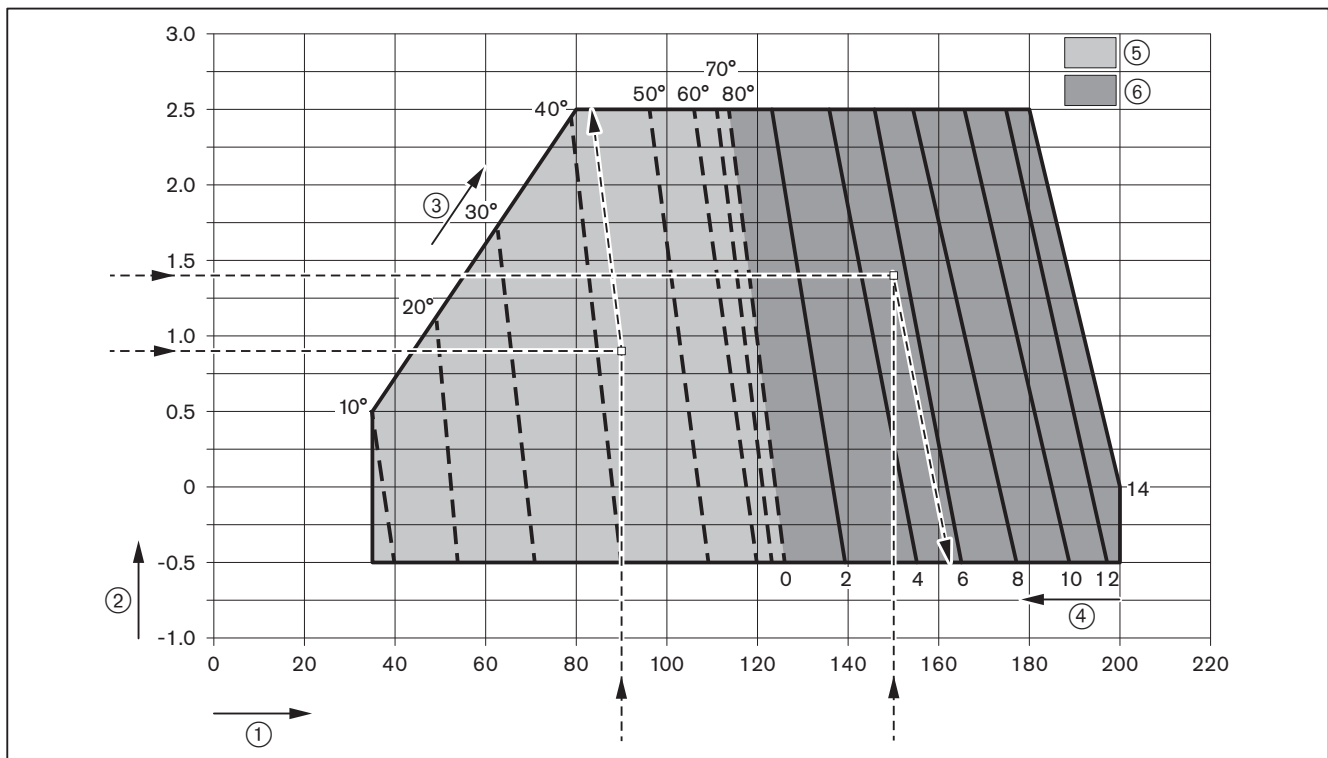

- ① Combustion heat rating [kW]
- ② Combustion chamber pressure [mbar]
- ③ Air damper setting
- ④ Diffuser setting (dimension X) [mm]
- ⑤ Air damper setting range with diffuser setting closed (X = 0 mm)
- ⑥ Setting range dimension X with air damper setting > 80°



**Set diffuser**

With dimension  $X = 0$  mm the indicating bolt is flush with the cover of the nozzle assembly.

- ▶ Turn screw ①, until dimension  $X$  equals the value determined.

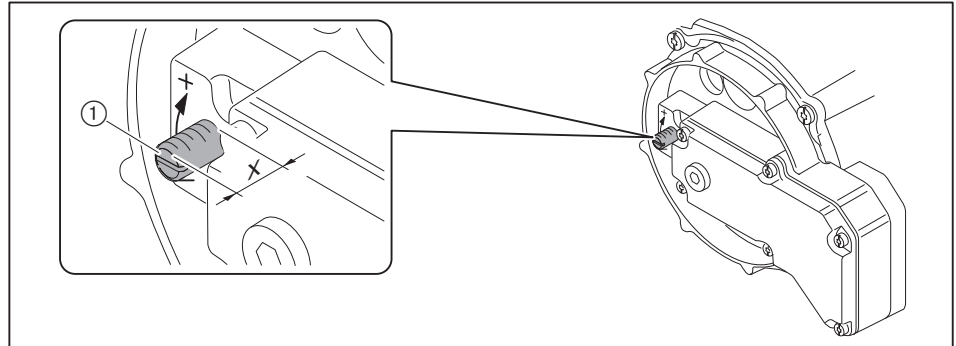

**7.1.7 Preset gas and air pressure switch**

The presetting of the pressure switches is only valid during commissioning. Once commissioning has been completed the pressure switches must be set correctly [ch. 7.3].

Air pressure switch	approx. 3.5 mbar
Low gas pressure switch/valve proving gas pressure switch	12 mbar
High gas pressure switch (optional)	approx. twice control pressure

## 7.2 Adjusting the burner

### 7.2.1 Burner without variable speed drive



#### Risk of electric shock

Touching the ignition device can lead to electric shock.

- ▶ Do not touch ignition device during the ignition process.

- ▶ Check flame signal during commissioning [ch. 7.1.1].

#### 1. Preset combustion manager

- ▶ Unplug bridging plug No. 7 on combustion manager.
- ▶ Switch on voltage supply.
- ✓ Combustion manager drives to Standby.



- ▶ Press [G] and [L/A] keys simultaneously.
- ✓ Combustion manager changes to access level.



- ▶ Press [+] key.
- ✓ Combustion manager changes into the setting level for step points.

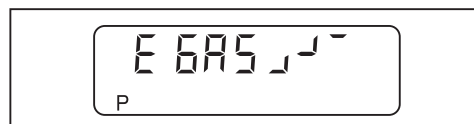

- ▶ Press [+] key.
- ✓ Factory setting operating point P9 (full load) is displayed.



- ▶ Press and hold [L/A] key and set air damper setting determined using the [-] or [+] key [ch. 7.1.6].
- ▶ Press and hold [G] key using [-] or [+] key set gas butterfly valve to the same value.
- ▶ Press [+] key.
- ✓ Factory setting operating point P1 (partial load) is displayed.



- ▶ Press [+] button to confirm factory setting.
- ✓ Factory setting operating point P0 (ignition position) is displayed.



- ▶ Press [+] button to confirm factory setting.
- ✓ Combustion manager is preset.

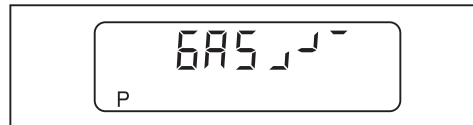

## 2. Check sequence of operation

- ▶ Open gas isolation valve.
- ✓ Pressure in gas valve train increases.
- ▶ Close isolation valve.
- ▶ Plug in bridging plug No. 7 on combustion manager.
- ✓ Burner starts.
- ✓ Valve proving is carried out.
- ▶ Check sequence of operation:
  - valves open
  - gas pressure switch reacts
  - burner start is interrupted
  - burner does not detect a flame and goes to lockout

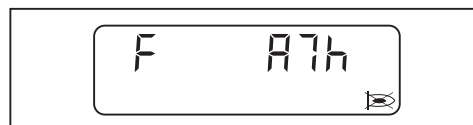

- ▶ Reset burner using the [ENTER] key.
- ✓ Combustion manager drives to Standby.



7 Commissioning

3. Preset setting pressure



If a controlled shutdown or lockout occurs during setting:

- ▶ Briefly press [G] and [L/A] keys simultaneously.
- ▶ Press [+] key.
- ✓ Combustion manager changes to setting level.

- ▶ Open test point for setting pressure and connect pressure measuring device.

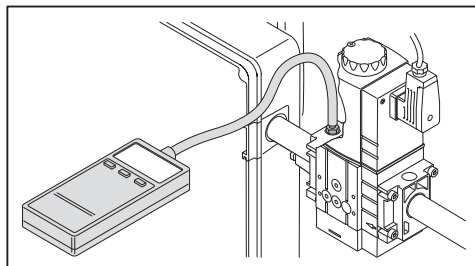

- ▶ Open gas isolation valve.
- ▶ Briefly press [-] and [+] keys simultaneously.
- ✓ The display shows E ACCESS.



- ▶ Press [+] key.

Burner starts according to the sequence of operation and stops at operating point P0 (ignition position).

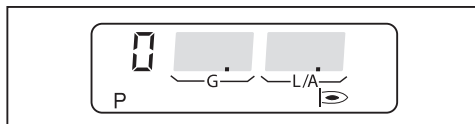

- ▶ Preset setting pressure determined at multifunction assembly [ch. 7.1.5].
- ▶ Check CO content of combustion and if necessary adjust combustion values via gas butterfly valve setting [G].

**4. Drive to full load**

- ▶ Press [+] key.
- ✓ Burner drives to operating point P1.

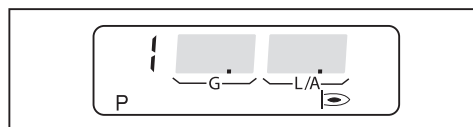

- ▶ Check CO content of combustion and if necessary adjust combustion values via gas butterfly valve setting [G].
- ▶ Press [+] key.
- ✓ Next operating point is initiated.
- ▶ Repeat steps at each operating point until P9 has been reached.

**5. Adjust full load**

If the burner is operated with a hydrogen content of > 10 % in the natural gas, observe the supplementary manual with hydrogen content (Print No. 835927xx).

When adjusting, the ratings data given by the boiler manufacturer and the capacity graph of the burner should be observed [ch. 3.4.6].

- ▶ Calculate gas throughput (operating volume  $V_B$ ) required [ch. 7.6].
- ▶ Optimise setting pressure and/or gas butterfly valve setting [G] until gas throughput ( $V_B$ ) has been reached.
- ▶ Check combustion values.
- ▶ Determine combustion limit and set excess air via air damper setting [L/A], see [ch. 7.5].
- ▶ Determine gas throughput once more and adjust if necessary.
- ▶ Re-set excess air.



The setting pressure must not be altered once this work has been completed.

7 Commissioning

6. Adjusting operating point P1

- ▶ Press [-] key.
- ✓ P9 is saved.
- ✓ Burner drives to operating point P8.

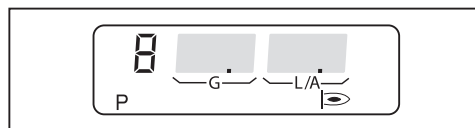

- ▶ Check CO content of combustion and if necessary adjust combustion values via gas butterfly valve setting [G].
- ▶ Press [-] key.
- ✓ Next operating point is initiated.
- ▶ Repeat steps at each operating point until P1 has been reached.



Operating point P1 must lie within the capacity graph [ch. 3.4.6].

- ▶ Determine gas throughput and if necessary adjust via gas butterfly valve setting [G].
- ▶ Check combustion values.
- ▶ Determine combustion limit and set excess air of approx. 20 ... 25 % via air damper setting [L/A].

7. Adjust ignition load

- ▶ Press [-] key.
- ✓ Burner drives to operating point P0 (ignition position).

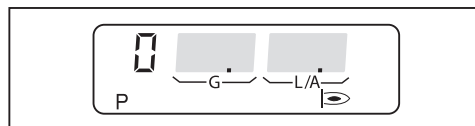

- ▶ Check combustion values in operating point P0 (ignition position).
- ▶ Set O<sub>2</sub> content of 4 ... 5 % above gas butterfly valve setting [G].
- ▶ Check mixing pressure

The mixing pressure in ignition position must be between 0.5 ... 2.0 mbar.

- ▶ If necessary, adjust mixing pressure via air damper setting [L/A].

**8. Perform linearisation [ch. 6.3]**

- ▶ Press [+] key.
- ✓ Burner drives to operating point P1.

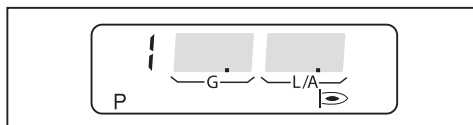

- ▶ Press [Enter].
- ✓ Combustion manager changes to linearisation mode.

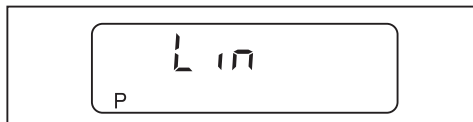

- ▶ Confirm with [+] key.
- ✓ Linearisation is initiated.
- ✓ The display then shows operating point P1.
- ✓ Calculation from P1 to P9 was carried out.

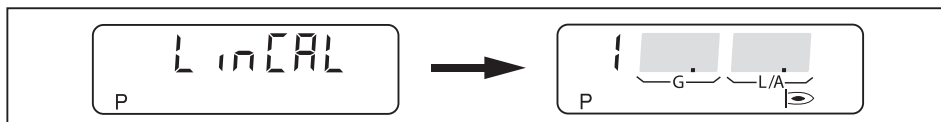

**9. Optimising the operating points**

- ▶ Check combustion values.
- ▶ Press and hold [G] and optimise combustion values using [-] or [+] key.
- ▶ Press [+] key.
- ✓ Next operating point is initiated.
- ▶ Repeat steps at each operating point until P9 has been reached.



- ▶ Press [G] and [L/A] keys simultaneously.
- ✓ The upper operating limit (bo) is displayed.

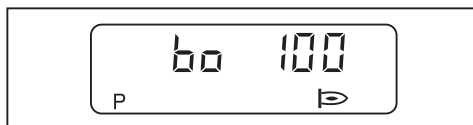

7 Commissioning

10. Adjust partial load

- ▶ Press [G] and [L/A] keys simultaneously.
- ✓ Burner drives to partial load.
- ✓ The lower operating limit is displayed (bu).

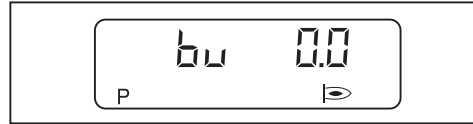

- ▶ Define partial load whilst observing:
  - data supplied by boiler manufacturer
  - burner capacity graph [ch. 3.4.6]
- ▶ Determine gas throughput and if necessary adjust partial load (bu) using [+] key.
- ▶ Press [G] and [L/A] keys simultaneously.
- ✓ Combustion manager changes to operating level (10).
- ✓ Combustion manager is programmed.



11. Check start behaviour

- ▶ Switch off and restart burner.
- ▶ Check start behaviour and if necessary correct operating point P0 (ignition position).

If the ignition position has been altered:

- ▶ Re-check start behaviour.



## 7.2.2 Burner with variable speed drive (optional)



### Risk of electric shock

Touching the ignition device can lead to electric shock.

- ▶ Do not touch ignition device during the ignition process.

- ▶ Check flame signal during commissioning [ch. 7.1.1].

### 1. Preset combustion manager

- ▶ Unplug bridging plug No. 7 on combustion manager.
- ▶ Switch on voltage supply.
- ✓ Combustion manager drives to Standby.



- ▶ Press [G] and [L/A] keys simultaneously.
- ✓ Combustion manager changes to access level.



- ▶ Press [+] key.
- ✓ Combustion manager changes into the setting level for step points.

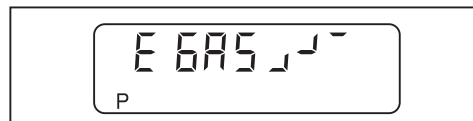

- ▶ Press [+] key.
- ✓ Factory setting operating point P9 (full load) is displayed.



- ▶ Press and hold [L/A] key and set air damper setting determined using the [-] or [+] key [ch. 7.1.6].
- ▶ Press and hold [G] key using [-] or [+] key set gas butterfly valve to the same value.
- ▶ Press [Enter] and [L/A] simultaneously.
- ✓ Factory setting fan speed (100 %) is displayed.

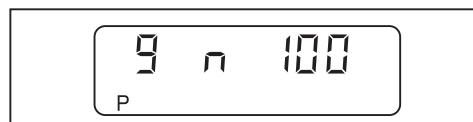

7 Commissioning

- ▶ Press [+] key.
- ✓ Factory setting operating point P1 (partial load) is displayed.



- ▶ Press [Enter] and [L/A] simultaneously.
- ✓ Factory setting fan speed (100 %) is displayed.

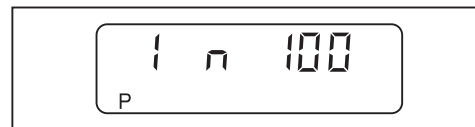

- ▶ Press [+] button to confirm factory setting.
- ✓ Factory setting operating point P0 (ignition position) is displayed.



- ▶ Press [Enter] and [L/A] simultaneously.
- ✓ Factory setting fan speed (70 %) is displayed.

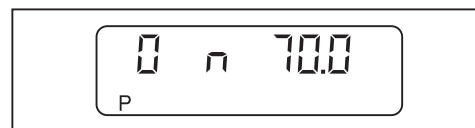

- ▶ Press [+] button to confirm factory setting.
- ✓ Combustion manager is preset.



**2. Check sequence of operation**

- ▶ Open gas isolation valve.
- ✓ Pressure in gas valve train increases.
- ▶ Close isolation valve.
- ▶ Plug in bridging plug No. 7 on combustion manager.
- ✓ Burner starts.
- ✓ Valve proving is carried out.

Speed standardisation is started.



- ▶ Press [+] key within 20 seconds.
- ✓ Speed standardisation is carried out.
- ✓ U and the current fan speed are displayed.

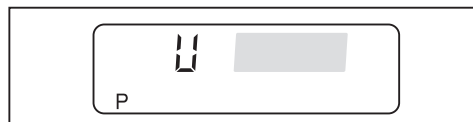

- ▶ Wait approx. 5 seconds, until the fan speed has stabilised.
- ▶ Press [+] key within 15 seconds.
- ✓ Speed standardisation is complete.
- ▶ Check sequence of operation:
  - valves open
  - gas pressure switch reacts
  - burner start is interrupted
  - burner does not detect a flame and goes to lockout

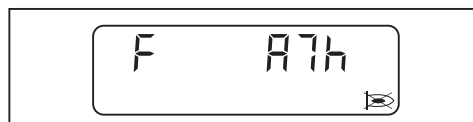

- ▶ Reset burner using the [ENTER] key.
- ✓ Combustion manager drives to Standby.



7 Commissioning

3. Preset setting pressure



If a controlled shutdown or lockout occurs during setting:

- ▶ Briefly press [G] and [L/A] keys simultaneously.
- ▶ Press [+] key.
- ✓ Combustion manager changes to setting level.

- ▶ Open test point for setting pressure and connect pressure measuring device.

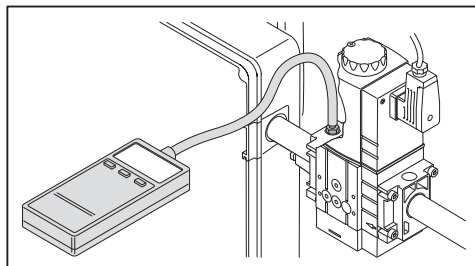

- ▶ Open gas isolation valve.
- ▶ Briefly press [-] and [+] keys simultaneously.
- ✓ The display shows E ACCESS.



- ▶ Press [+] key.

Burner starts according to the sequence of operation and stops at operating point P0 (ignition position).

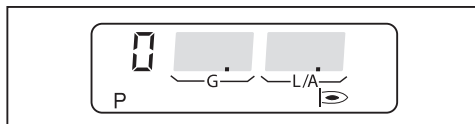

- ▶ Preset setting pressure determined at multifunction assembly [ch. 7.1.5].
- ▶ Check CO content of combustion and if necessary adjust combustion values via gas butterfly valve setting [G].

#### 4. Drive to full load

- ▶ Press [+] key.
- ✓ Burner drives to operating point P1.

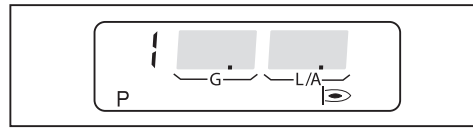

- ▶ Check CO content of combustion and if necessary adjust combustion values via gas butterfly valve setting [G].
- ▶ Press [+] key.
- ✓ Next operating point is initiated.
- ▶ Repeat steps at each operating point until P9 has been reached.



#### 5. Adjust full load

If the burner is operated with a hydrogen content of > 10 % in the natural gas, observe the supplementary manual with hydrogen content (Print No. 835927xx).

When adjusting, the ratings data given by the boiler manufacturer and the capacity graph of the burner should be observed [ch. 3.4.6].



Select speed at full load as low as possible, but not less than 90 %. Observe flame stability.

- ▶ Calculate gas throughput (operating volume  $V_B$ ) required [ch. 7.6].
- ▶ Optimise setting pressure and/or gas butterfly valve setting [G] until gas throughput ( $V_B$ ) has been reached.
- ▶ Check combustion values.
- ▶ Determine combustion limit, set excess air via air damper setting and speed.
- ▶ Determine gas throughput once more and adjust if necessary.
- ▶ Re-set excess air.



The setting pressure must not be altered once this work has been completed.

7 Commissioning

6. Adjusting operating point P1

- ▶ Press [-] key.
- ✓ P9 is saved.
- ✓ Burner drives to operating point P8.

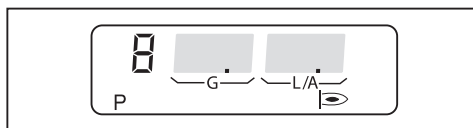

- ▶ Check CO content of combustion and if necessary adjust combustion values via gas butterfly valve setting [G].
- ▶ Press [-] key.
- ✓ Next operating point is initiated.
- ▶ Repeat steps at each operating point until P1 has been reached.



The speed at operating point P1 must not be less than 30 %.  
Recommended speed: 50 %.

A minimum speed of 50 % should be aimed for in operating point P1 whilst observing combustion values and flame stability.

- ▶ Slowly reduce speed using [L/A] and [ENTER] key, whilst opening air damper setting alternately using the [L/A] key.

Operating point P1 must lie within the capacity graph [ch. 3.4.6].

- ▶ Determine gas throughput and if necessary adjust via gas butterfly valve setting [G].
- ▶ Check combustion values.
- ▶ Determine combustion limit and set excess air of approx. 20 ... 25 % via air damper setting [L/A].

7. Adjust ignition load



The ignition speed must not be less than 70 %.

- ▶ Press [-] key.
- ✓ Burner drives to operating point P0 (ignition position).

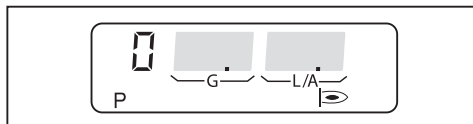

- ▶ Check combustion values in operating point P0 (ignition position).
- ▶ Set O<sub>2</sub> content of 4 ... 5 % above gas butterfly valve setting [G].
- ▶ Check mixing pressure

The mixing pressure in ignition position must be between 0.5 ... 2.0 mbar.

- ▶ If necessary, adjust mixing pressure via air damper setting [L/A].

**8. Perform linearisation [ch. 6.3]**

- ▶ Press [+] key.
- ✓ Burner drives to operating point P1.

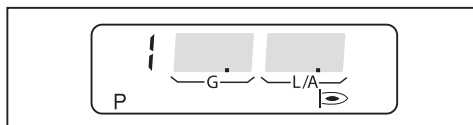

- ▶ Press [Enter].
- ✓ Combustion manager changes to linearisation mode.

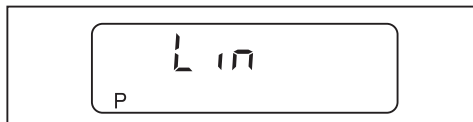

- ▶ Confirm with [+] key.
- ✓ Linearisation is initiated.
- ✓ The display then shows operating point P1.
- ✓ Calculation from P1 to P9 was carried out.

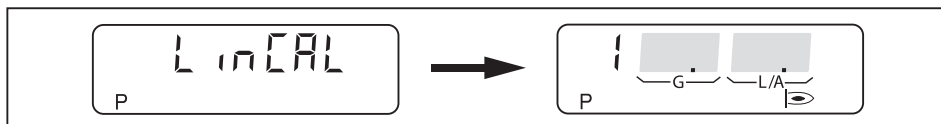

**9. Optimising the operating points**

- ▶ Check combustion values.
- ▶ Press and hold [G] and optimise combustion values using [-] or [+] key.
- ▶ Press [+] key.
- ✓ Next operating point is initiated.
- ▶ Repeat steps at each operating point until P9 has been reached.



- ▶ Press [G] and [L/A] keys simultaneously.
- ✓ The upper operating limit (bo) is displayed.

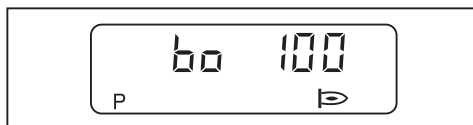

7 Commissioning

10. Adjust partial load

- ▶ Press [G] and [L/A] keys simultaneously.
- ✓ Burner drives to partial load.
- ✓ The lower operating limit is displayed (bu).



- ▶ Define partial load whilst observing:
  - data supplied by boiler manufacturer
  - burner capacity graph [ch. 3.4.6]
- ▶ Determine gas throughput and if necessary adjust partial load (bu) using [+] key.
- ▶ Press [G] and [L/A] keys simultaneously.
- ✓ Combustion manager changes to operating level (10).
- ✓ Combustion manager is programmed.



11. Check start behaviour

- ▶ Switch off and restart burner.
- ▶ Check start behaviour and if necessary correct operating point P0 (ignition position).

If the ignition position has been altered:

- ▶ Re-check start behaviour.



## 7.3 Set pressure switches

### 7.3.1 Set gas pressure switch

#### Low gas pressure switch/valve proving gas pressure switch

The switch point must be checked and if necessary adjusted during commissioning.

- ▶ Connect pressure measuring device to test point ① of the low gas pressure switch.
- ▶ Start burner and drive to full load.
- ▶ Slowly close gas isolation valve until either:
  - the O<sub>2</sub> content in the flue gas increases to above 7 %
  - the flame stability worsens considerably
  - the CO content increases
  - the gas pressure reaches 12 mbar
  - or the gas pressure drops to 50 %
- ▶ Determine gas pressure.
- ▶ Slowly open gas isolation valve.
- ▶ Set the pressure determined as switch point at the setting cam ②, minimum value 12 mbar.

#### Check switch point

- ▶ Restart the burner.
- ▶ Slowly close gas isolation valve.
- ✓ If the low gas program starts, the gas pressure switch has been set correctly.
- ✓ If a lockout occurs or if the combustion reaches a critical condition, the low gas pressure switch reacts too late.

If lockout occurs:

- ▶ Increase switch point at setting cam ②.
- ▶ Slowly open gas isolation valve.
- ▶ Re-check switch point.

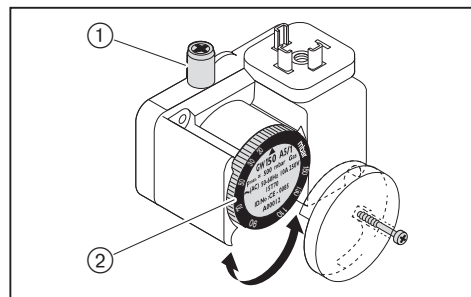

#### Set (optional) high gas pressure switch

Depending on the burner application, optional equipment may be required for optimum operation [ch. 12.2].

- ▶ Set high gas pressure switch to  $1.3 \times P_{\text{Gas full load}}$  (gas flow pressure at full load).

7 Commissioning

7.3.2 Set air pressure switch

The switch point must be checked and if necessary adjusted during commissioning.

- ▶ Connect pressure measuring device for differential pressure measurement.
- ▶ Start the burner.
- ▶ Carry out differential pressure measurement across the whole capacity range of the burner and determine the lowest differential pressure.
- ▶ Calculate switch point (80 % of release pressure or lowest differential pressure).
- ▶ Set the switch point determined at the setting cam ①.

Example

Lowest differential pressure	4.4 mbar
Switch point air pressure switch (80 %)	$4.4 \text{ mbar} \times 0.8 = 3.5 \text{ mbar}$

Site specific influences on the air pressure, (e. g. by the flue gas system, heat exchanger, installation location or air supply) may make it necessary to vary the setting of the air pressure switch.

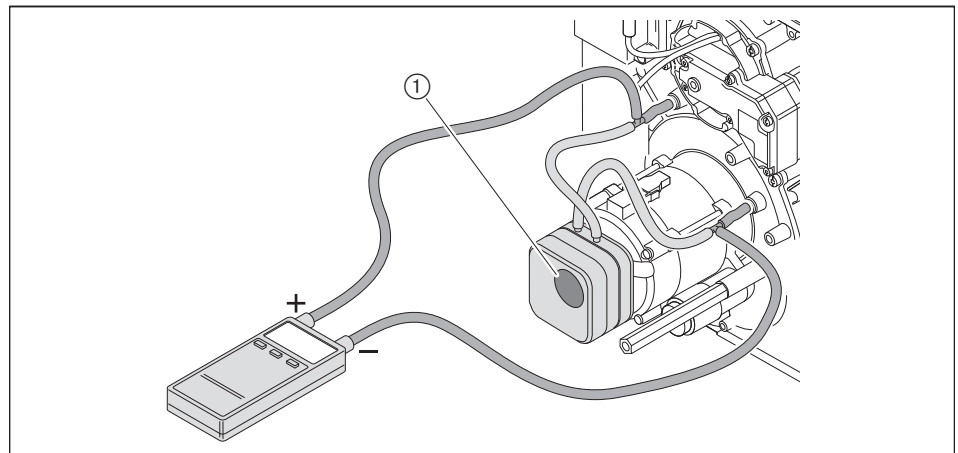

### 7.4 Concluding work

- ▶ Check control and safety devices.
- ▶ Remove gas pressure measuring devices and close all test points.
- ▶ Conclude valve proving of gas valve train (fourth test phase) [ch. 7.1.3].
- ▶ Enter type and serial number into the text box [ch. 3.2].
- ▶ Enter combustion values and settings in the commissioning record and/or test sheet.
- ▶ Enter setting values on the sticker ① supplied.
- ▶ Adhere sticker to the burner.
- ▶ Mount cover on burner.
- ▶ Inform the operator about the use of the equipment.
- ▶ Hand the installation and operating manual to the operator and inform him that this should be kept with the appliance.
- ▶ Point out to operator that the installation should be serviced annually.

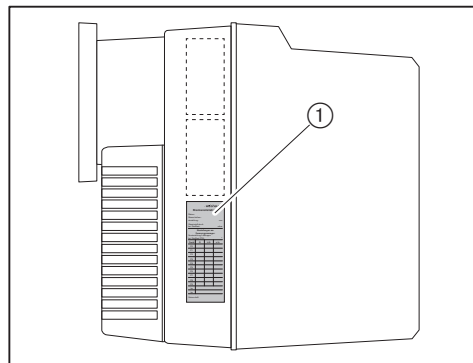

7 Commissioning

7.5 Check combustion

If the burner is operated with a hydrogen content of > 10 % in the natural gas, observe the supplementary manual with hydrogen content (Print No. 835927xx).

Determine excess air

- ▶ Slowly close air damper(s) in the relevant operating point, until the combustion limit is reached (CO content approx. 100 ppm).
- ▶ Measure and document O<sub>2</sub> content.
- ▶ Read air number (λ).

Increase air number to ensure sufficient excess air:

- by 0.15 ... 0.20 (equates to 15 ... 20 % excess air)
- by more than 0.20 for more difficult conditions, such as:
  - dirty combustion air
  - fluctuating intake temperature
  - fluctuating chimney draught

Example

$$\lambda + 0.15 = \lambda^*$$

- ▶ Set air number (λ\*), do not exceed CO content of 50 ppm.
- ▶ Measure and document O<sub>2</sub> content.

Check flue gas temperature

- ▶ Check flue gas temperature.
- ▶ Ensure that the flue gas temperature complies with the data provided by the boiler manufacturer.
- ▶ If necessary adjust flue gas temperature, e. g.:
  - increase burner capacity in partial load to avoid condensation in the flue gas ducts, except on condensing units
  - reduce burner capacity in full load to improve efficiency
  - adjust heat exchanger to the data provided by the manufacturer

Determine flue gas losses

- ▶ Drive to full load.
- ▶ Measure combustion air temperature (t<sub>L</sub>) near the air damper(s).
- ▶ Measure oxygen content (O<sub>2</sub>) and flue gas temperature (t<sub>A</sub>) at the same time at one point.
- ▶ Determine flue gas losses using the following formula:

$$q_A = (t_A - t_L) \cdot \left( \frac{A_2}{21 - O_2} + B \right)$$

- q<sub>A</sub> Flue gas losses [%]
- t<sub>A</sub> Flue gas temperature [°C]
- t<sub>L</sub> Combustion air temperature [°C]
- O<sub>2</sub> Volumetric content of oxygen in dry flue gas [%]

Fuel factors	Natural Gas	Liquid Petroleum Gas
A2	0.66	0.63
B	0.009	0.008

### 7.6 Calculate gas throughput

Formula symbol	Description	Example values
$V_B$	Operating volume [m <sup>3</sup> /h] Volume measured at gas meter at current pressure and temperature (gas throughput).	–
$V_N$	Standard volume [m <sup>3</sup> /h] Volume gained by gas at 1013 mbar and 0 °C.	–
$f$	Conversion factor	–
$Q_N$	Heat rating [kW]	200 kW
$\eta$	Boiler efficiency (e. g. 92 % $\pm$ 0.92)	0.92
$H_i$	Calorific value [kWh/m <sup>3</sup> ] at 0 °C and 1013 mbar	10.35 kW/m <sup>3</sup> (Natural Gas E)
$t_{Gas}$	Gas temperature at gas meter [°C]	10 °C
$P_{Gas}$	Pressure at gas meter [mbar]	25 mbar
$P_{Baro}$	Barometric air pressure [mbar], see table	500 m $\pm$ 955 mbar
$V_G$	Gas throughput determined at gas meter	0.74 m <sup>3</sup>
$T_M$	Measuring time [seconds]	120 seconds

#### Calculate normal volume

- ▶ Calculate the normal volume ( $V_N$ ) using the following formula.

$$V_N = \frac{Q_N}{\eta \cdot H_i} \quad V_N = \frac{200 \text{ kW}}{0.92 \cdot 10.35 \text{ kW/m}^3} = 21.0 \text{ m}^3/\text{h}$$

#### Calculate conversion factor

- ▶ Determine gas temperature ( $t_{Gas}$ ) and pressure ( $P_{Gas}$ ) at gas meter.
- ▶ Determine barometric air pressure ( $P_{Baro}$ ) from table.

Height above sea level (m)	0	100	200	300	400	500	600	700	800	900	1000	1100	1200	1300
$P_{Baro}$ [mbar]	1013	1001	990	978	966	955	943	932	921	910	899	888	877	866

- ▶ Calculate conversion factor ( $f$ ) using the following formula.

$$f = \frac{P_{Baro} + P_{Gas}}{1013} \cdot \frac{273}{273 + t_{Gas}} \quad f = \frac{955 + 25}{1013} \cdot \frac{273}{273 + 10} = 0.933$$

#### Calculate operating volume (gas throughput) required

$$V_B = \frac{V_N}{f} \quad V_B = \frac{21.0 \text{ m}^3/\text{h}}{0.933} = 22.5 \text{ m}^3/\text{h}$$

#### Determine current operating volume (gas throughput)

- ▶ Measure gas throughput ( $V_G$ ) at gas meter, measuring time ( $T_M$ ) should be a minimum of 60 seconds.
- ▶ Calculate operating volume ( $V_B$ ) using the following formula.

$$V_B = \frac{3600 \cdot V_G}{T_M} \quad V_B = \frac{3600 \cdot 0.74 \text{ m}^3}{120 \text{ s}} = 22.2 \text{ m}^3/\text{h}$$

## 7 Commissioning

### 7.7 Subsequent optimisation of operating points

If necessary, the combustion values can subsequently be corrected.

- ▶ Unplug bridging plug No. 7 on combustion manager.
- ✓ Combustion manager drives to Standby.

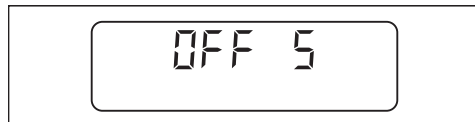

- ▶ Briefly press [-] and [+] simultaneously.
- ✓ Combustion manager changes to access level.



- ▶ Press [+].
- ✓ Combustion manager changes to setting level.

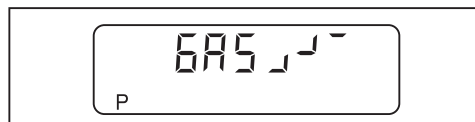

- ▶ Plug in bridging plug No. 7 on combustion manager.
- ✓ Burner starts and stops in operating point P0 (ignition position).
- ▶ Initiate the other operating points using the [+] or [-] key and optimise if required.

#### Exit setting level

- ▶ Press [G] and [L/A] simultaneously.
- ✓ The upper operating limit (bo) is displayed.
- ▶ Press [G] and [L/A] simultaneously.
- ✓ The lower operating limit is displayed (bu).
- ▶ Press [G] and [L/A] simultaneously.
- ✓ The combustion manager changes to operating level.

## **8 Shutdown**

In the event of operational failure:

- ▶ Switch off burner.
- ▶ Close fuel shut off devices.

## 9 Servicing

### 9.1 Notes on servicing



**DANGER**

#### Risk of explosion due to leaking gas

Improper service work can lead to escaping gas and explosion.

- ▶ Close fuel shut-off devices and secure against being switched on again unexpectedly prior to commencing work.
- ▶ Care should be taken when dismantling and assembling gas carrying components.
- ▶ Close the screws on the test points ensuring the test points are sealed.



**WARNING**

#### Risk of electric shock

Working on the device when voltage is applied can lead to electric shock.

- ▶ Isolate the device from the power supply prior to starting any work.
- ▶ Safeguard against accidental restart.



**WARNING**

#### Risk of electric shock

Touching the ignition device can lead to electric shock.

- ▶ Do not touch ignition device during the ignition process.



**WARNING**

#### Electric shock caused by frequency convertor

It is possible that electrical components continue to carry voltage and cause electric shock even after the voltage supply has been disconnected.

- ▶ Wait approx. 5 minutes before commencing work.
- ✓ Electric voltage has dissipated.



**CAUTION**

#### Danger of getting burned on hot components

Hot components can lead to burns.

- ▶ Do not touch the components.
- ▶ Allow components to cool.



**CAUTION**

#### Risk of injury from sharp edges

Sharp edges on components can cause injury.

- ▶ Wear protective gloves.
- ▶ Watch out for sharp edges.



**NOTICE**

#### Damage caused by objects in the burner housing

It is possible for objects to fall into the burner housing.

If these objects are not removed, they could damage the burner.

- ▶ Following servicing, ensure that there are no objects left in the burner housing.

Servicing must only be carried out by qualified personnel. The combustion plant should be serviced annually. Depending on site conditions more frequent checks may be required.

Components, which show increased wear and tear or whose design lifespan is or will be exceeded prior to the next service should be replaced as a precaution.

The design lifespan of the components is listed in the service plan [ch. 9.2].



Weishaupt recommends a service contract is entered into to ensure regular inspections.



The following components must only be replaced and must not be repaired:

- Combustion Manager
- Flame sensor
- Actuator
- Multifunction assembly
- Pressure regulator
- Pressure switch

#### **Prior to every servicing**

- ▶ Inform the operator about the extent of service work to be carried out.
- ▶ Switch off mains switch of installation and safeguard against accidental reactivation.
- ▶ Close fuel shut-off devices and secure against being switched on again unexpectedly.
- ▶ Remove cover.
- ▶ Unplug boiler control connection plug from combustion manager.

#### **Following servicing**

- ▶ Check tightness of gas carrying components.
- ▶ Check function of:
  - Ignition
  - Flame monitoring
  - Gas carrying components (gas connection pressure and setting pressure)
  - Pressure switch
  - Control and safety devices
- ▶ Check combustion values, if necessary re-adjust the burner.
- ▶ Enter combustion values and settings in the commissioning record.
- ▶ Enter setting values on the sticker supplied.
- ▶ Adhere sticker to the burner.
- ▶ Refit cover.

9 Servicing

9.2 Service plan

Components	Criteria / design lifespan <sup>(1)</sup>	Service procedure
Ignition electrode	Soiling	▶ Clean
	Damage / wear	▶ Replace [ch. 9.5] Recommendation: at least every 2 years
Ignition cable	Damage	▶ Replace
Ionisation electrode	Soiling	▶ Clean
	Damage / wear	▶ Replace [ch. 9.5] Recommendation: at least every 2 years
Ionisation cable	Damage	▶ Replace
Flame tube / diffuser	Soiling	▶ Clean
	Damage	▶ Replace
Fan wheel	Soiling	▶ Clean
	Damage	▶ Replace [ch. 9.7]
Air duct	Soiling	▶ Clean
Air damper	Soiling	▶ Clean
Combustion Manager	250 000 burner starts or 10 years <sup>(2)</sup>	▶ Replacement recommended [ch. 9.17].
Flame sensor	Damage	▶ Replace
	250 000 burner starts or 10 years <sup>(2)</sup>	
Breather plug multifunction assembly	Soiling	▶ Replace [ch. 9.15]
Filter insert multifunction assembly	Soiling	▶ Replace [ch. 9.16]
Multifunction assembly with valve testing system (valve proving)	Fault identified	▶ Replace
Multifunction assembly without valve testing system (valve proving)	Function / soundness	▶ Replace
	less than DN 25: 200 000 burner starts or 10 years <sup>(2)</sup>	
	DN 25 to DN 65: 100 000 burner starts or 10 years <sup>(2)</sup>	
Gas pressure regulator	Setting pressure	▶ Check [ch. 7.1.5].
	Function / soundness	▶ Replace
	15 years	
Air pressure switch	Switch point	▶ Check [ch. 7.3] [ch. 7.3.2].
	250 000 burner starts or 10 years <sup>(2)</sup>	▶ Replace
Gas pressure switch	Switch point	▶ Check [ch. 7.3.1].
	50 000 burner starts or 10 years <sup>(2)</sup>	▶ Replace

<sup>(1)</sup> The specified design lifespan applies for typical use in heating, hot-water and steam systems as well as for thermal process systems to EN ISO 13577-2.

<sup>(2)</sup> If a criterion is reached, carry out maintenance measures.

### 9.3 Removing and refitting mixing head

Observe notes on servicing [ch. 9.1].



#### Risk of explosion due to leaking gas

It is possible for gas to leak out if the gasket ③ is seated incorrectly.

- ▶ Following work on the mixing head, ensure the gasket is clean and seated correctly, if necessary replace.
- ▶ Check for leaks, see Fourth test phase [ch. 7.1.3].

#### Removing

- ▶ Unplug ionisation cable ⑤.
- ▶ Unplug ignition cable ①.
- ▶ Undo screws ④.
- ▶ Turn mixing head ② to the left up to the recess and remove.

#### Refitting

- ▶ Refit mixing head in reverse order ensuring correct alignment and cleanliness of gasket ③.

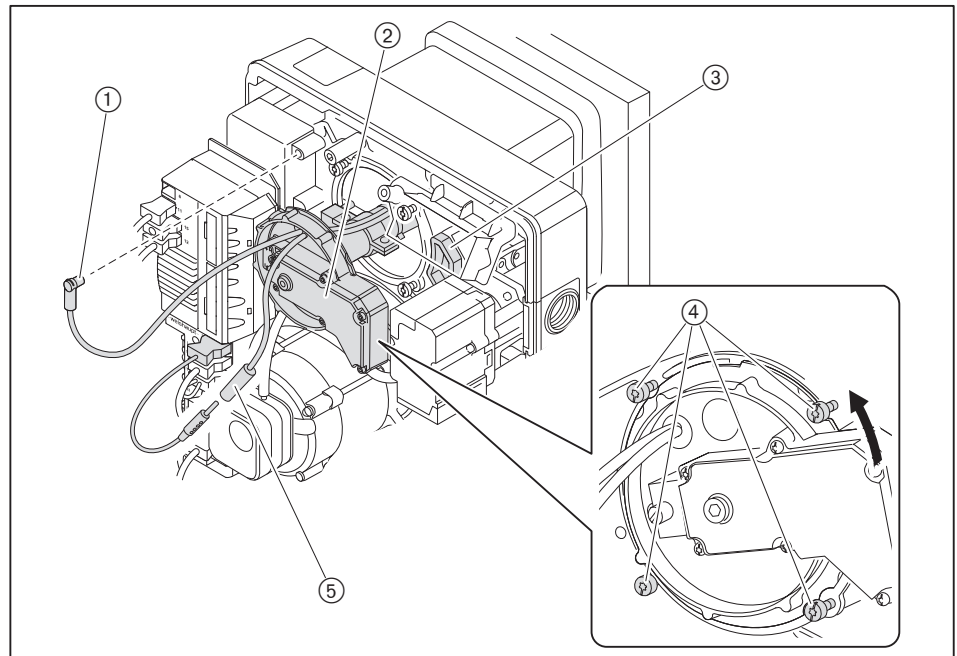

9 Servicing

9.4 Set mixing head

Observe notes on servicing [ch. 9.1].

The distance between diffuser and flame tube front edge S1 cannot be measured with the burner mounted. This is only possible indirectly with dimension Lx when the mixing head is removed.



Dimension Lx changes according to the combustion head extension used.

- ▶ Remove mixing head [ch. 9.3].
- ▶ Turn setting screw ① until it is flush with the nozzle assembly cover (dimension X = 0 mm).
- ▶ Check dimension Lx.

If the value measured deviates from dimension Lx:

- ▶ Undo screws ②.
- ▶ Adjust flame tube ③ until dimension Lx has been reached.
- ▶ Re-tighten screws ②.

If the screws ② have been loosened:

- ▶ Check position of electrodes and gas orifices ④.

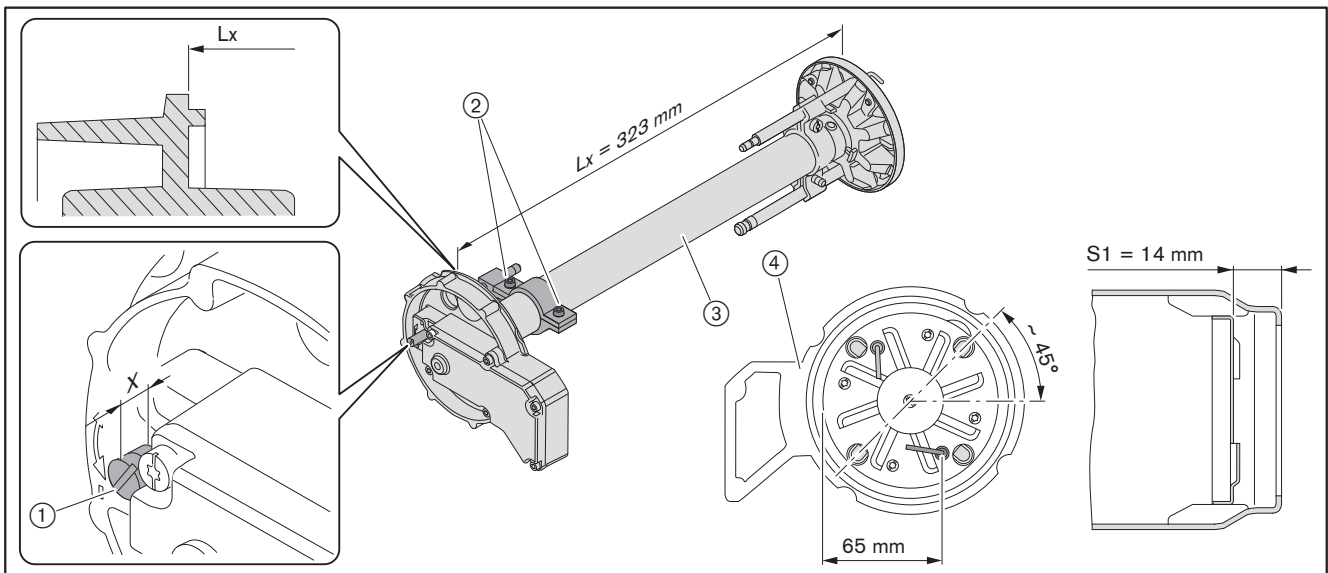

### 9.5 Set ionisation and ignition electrodes

Observe notes on servicing [ch. 9.1].

- ▶ Remove mixing head [ch. 9.3].
- ▶ Undo screw ①.
- ▶ Set ignition electrode and tighten screw ①.
- ▶ Undo screw ②.
- ▶ Set ionisation electrode and tighten screw ②.

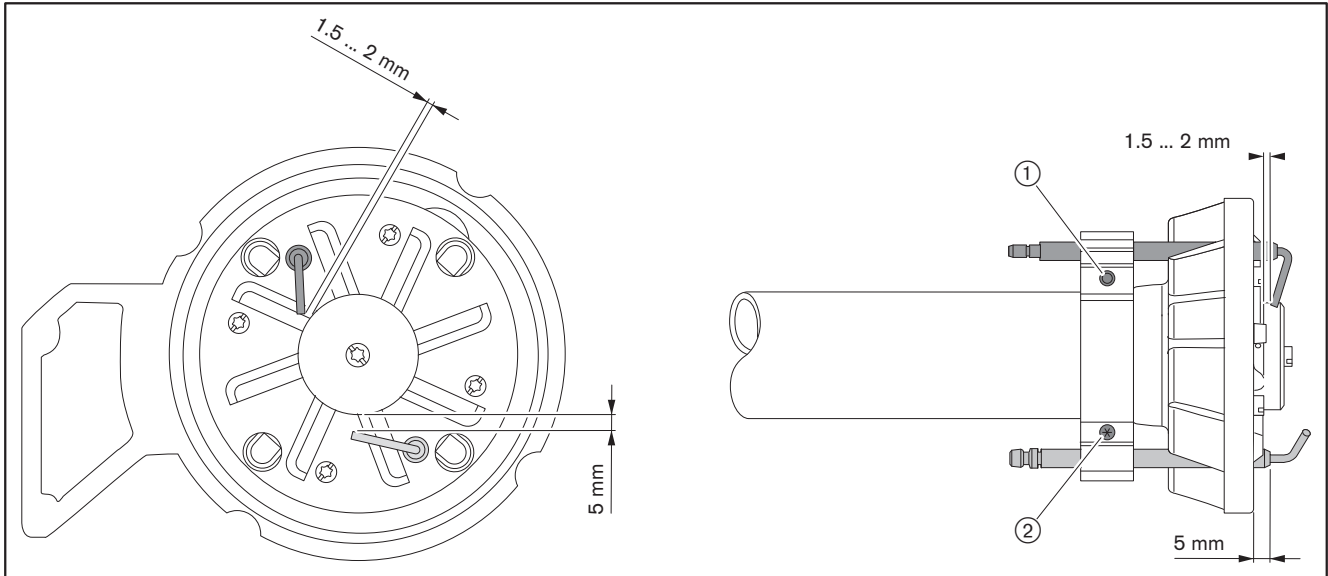

### 9.6 Service position

Observe notes on servicing [ch. 9.1].



The burner mounted rotated by 180° cannot be placed into the service position.

- ▶ Remove mixing head [ch. 9.3].
- ▶ Remove cover ② and remove plugs.
- ▶ Hold housing cover and remove screws ①.
- ▶ Place housing cover onto hanging bolts ③.

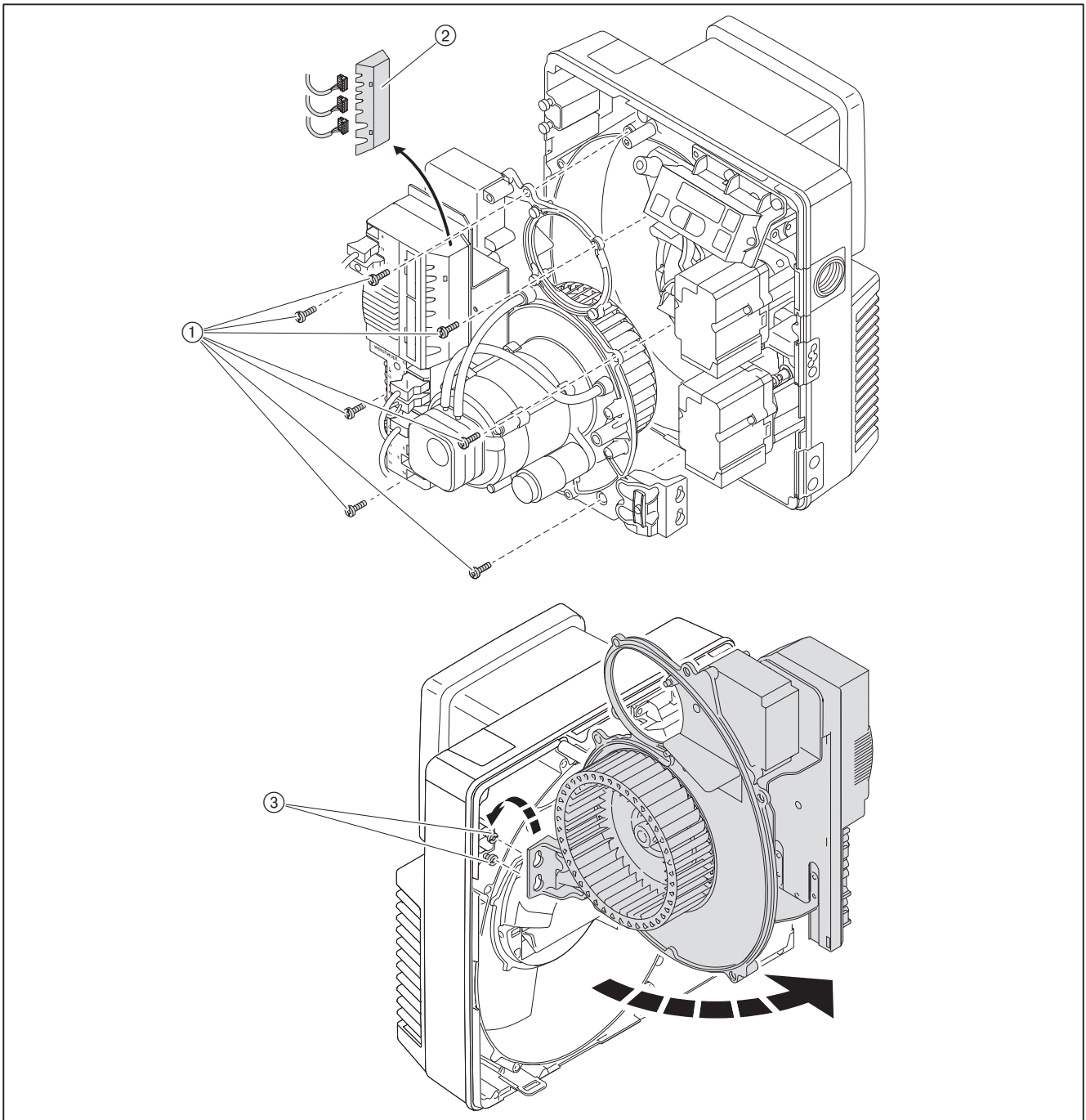



### 9.7 Removing and refitting fan wheel

Observe notes on servicing [ch. 9.1].

Personal protective equipment must be observed [ch. 2.4.1].

#### Removing

- ▶ Place housing cover into service position [ch. 9.6].
- ▶ Remove grub screw ① and remove fan wheel.

#### Refitting

- ▶ Refit fan wheel in reverse order and
  - ensure correct alignment on the motor shaft ②
  - screw in new grub screw ①
  - turn fan wheel to ensure it moves freely

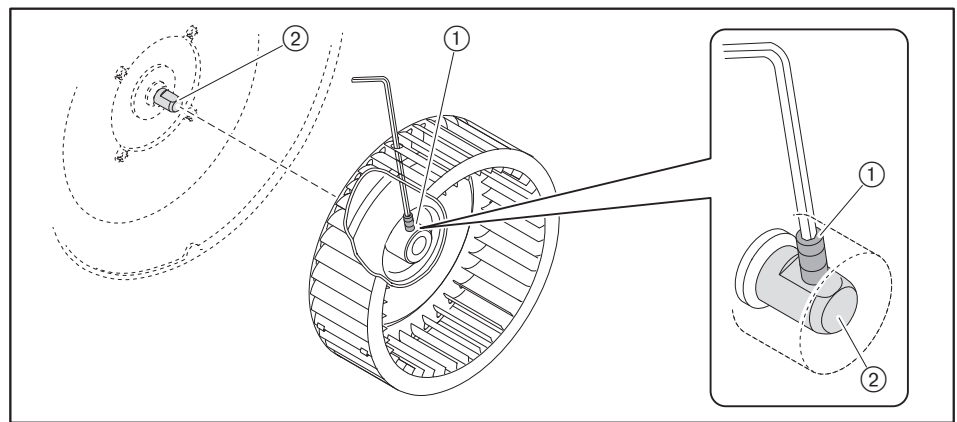

### 9.8 Remove burner motor

Observe notes on servicing [ch. 9.1].

- ▶ Remove fan wheel [ch. 9.7].
- ▶ Unplug plug number 3 and 11.
- ▶ Disconnect + and - hoses.
- ▶ Undo screws ① and remove air pressure switch.
- ▶ Hold motor and remove screws ②.
- ▶ Remove motor.

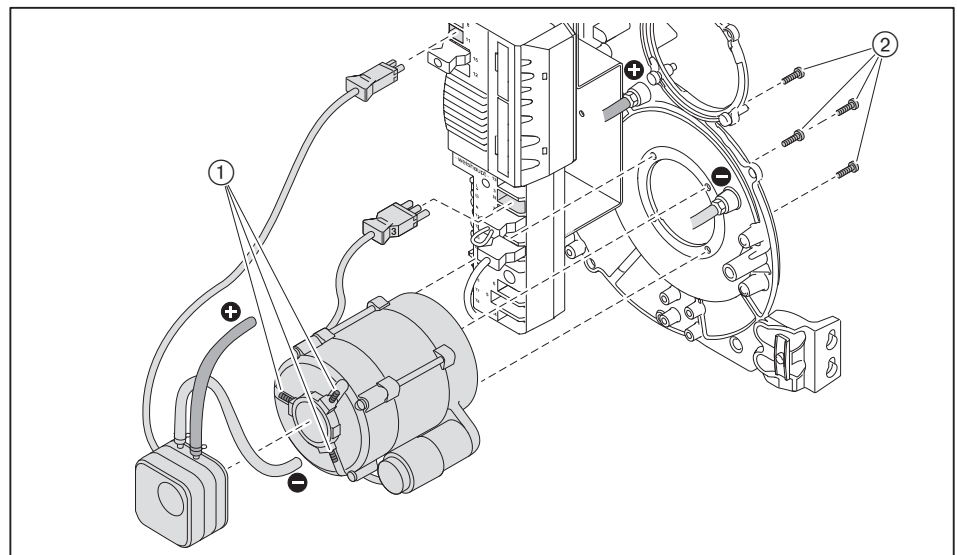

9 Servicing

9.9 Removing and refitting air damper actuator

Observe notes on servicing [ch. 9.1].

Removing

- ▶ Remove actuator plug ④ from combustion manager.
- ▶ Remove screws ③.
- ▶ Remove actuator and shaft ②.

Refitting



NOTICE

Damage to the actuator caused by turning the hub

Actuator could be damaged.

- ▶ Do not turn hub manually or with tool.

- ▶ Plug in actuator plug ④ at the combustion manager.
- ▶ Unplug bridging plug No. 7 on combustion manager.
- ▶ Switch on voltage supply.
- ✓ The combustion manager checks the actuator and drives to the reference point.
- ▶ Interrupt voltage supply.
- ▶ Fit shaft ② to actuator.
- ▶ Set indicator ① on angle drive to 0 (air damper Closed) and hold.
- ▶ Fit shaft with actuator to angle drive.
- ▶ Secure actuator.
- ▶ Plug in bridging plug No. 7 on combustion manager.

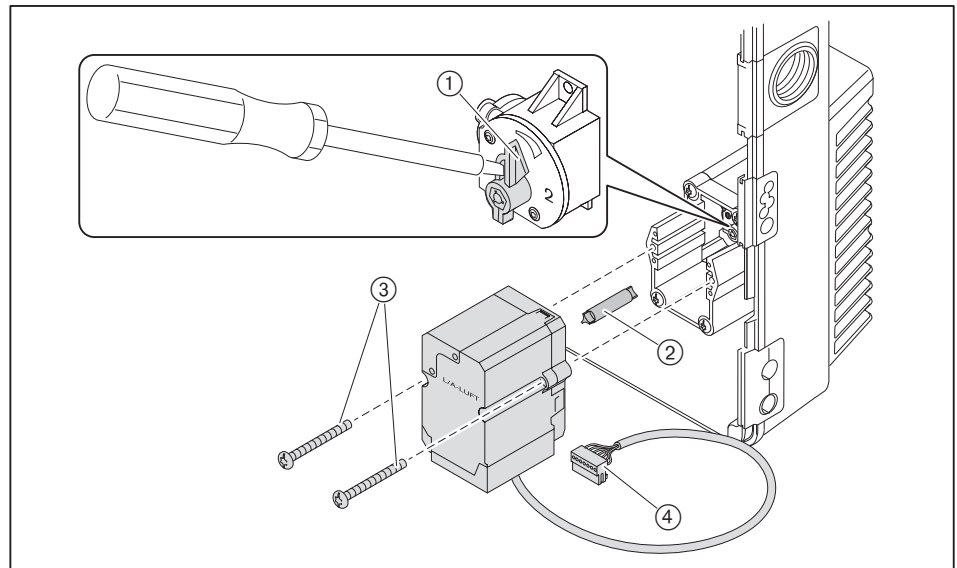



## 9.10 Removing and refitting angle drive

Observe notes on servicing [ch. 9.1].

### Removing

- ▶ Remove air damper actuator [ch. 9.9].
- ▶ Remove frame ①.
- ▶ Remove angle drive ②.

### Refitting

- ▶ Remove intake housing.
- ▶ Open air damper ③ until position ④ has been reached and hold tight.
- ▶ Fit angle drive to shaft.
- ▶ Secure angle drive.
- ▶ Mount intake housing.
- ▶ Fit frame ①.

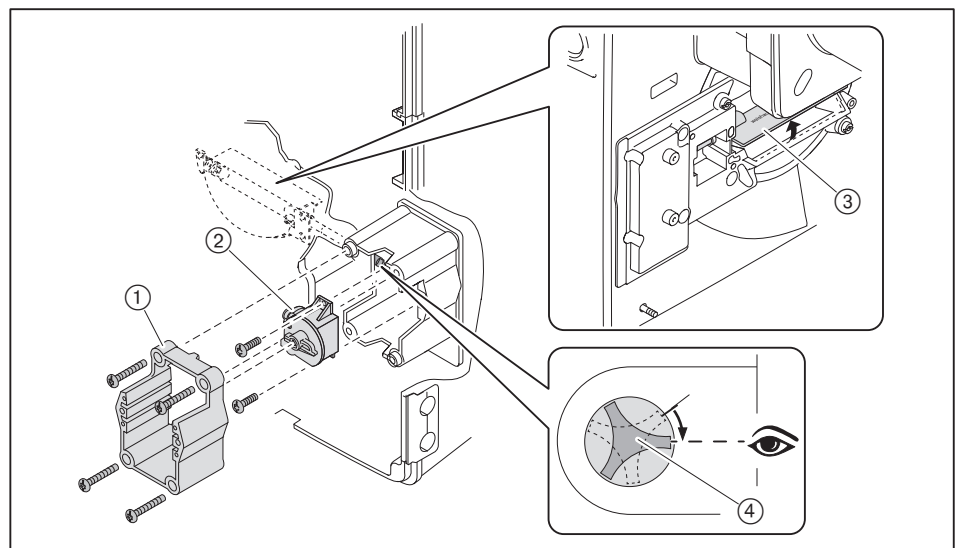

9 Servicing

9.11 Removing and refitting gas butterfly valve actuator

Observe notes on servicing [ch. 9.1].

Removing

- ▶ Remove actuator plug ① from combustion manager.
- ▶ Remove screws ②.
- ▶ Remove actuator.

Refitting



NOTICE

Damage to the actuator caused by turning the hub

Actuator could be damaged.

- ▶ Do not turn hub manually or with tool.

- ▶ Plug in actuator plug ① at the combustion manager.
- ▶ Unplug bridging plug No. 7 on combustion manager.
- ▶ Switch on voltage supply.
- ✓ The combustion manager checks the actuator and drives to the reference point.
- ▶ Interrupt voltage supply.
- ▶ Fit actuator rotated by approx. 15°.
- ▶ Secure actuator.
- ▶ Plug in bridging plug No. 7 on combustion manager.

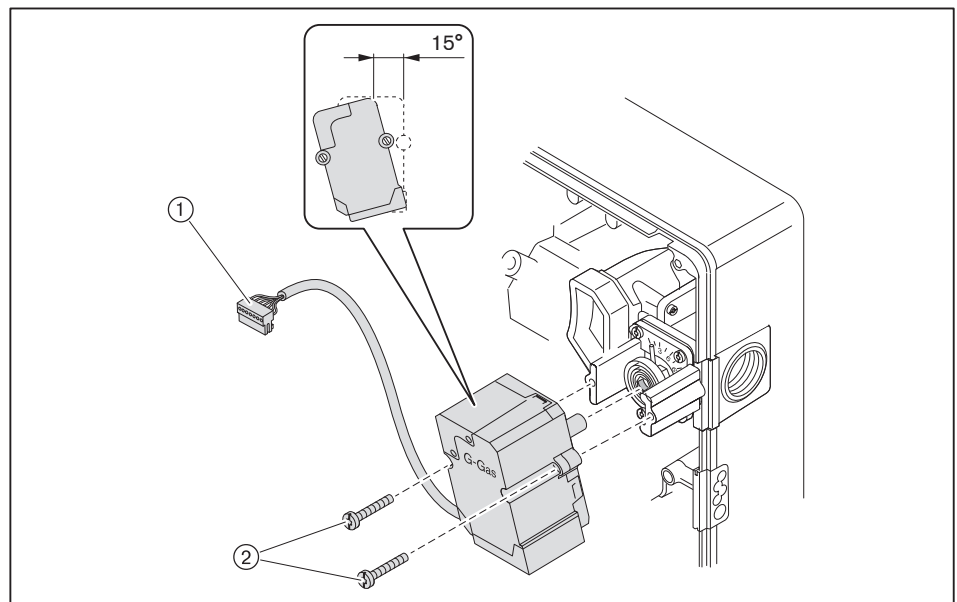

### 9.12 Removing and refitting gas butterfly valve

Observe notes on servicing [ch. 9.1].

#### Removing

- ▶ Remove screws ③.
- ▶ Unscrew flange with double nipple ④.
- ▶ Remove mixing head [ch. 9.3].
- ▶ Remove screws ① and remove gas butterfly valve ②.

#### Refitting

- ▶ Refit gas butterfly valve ② in reverse order, secure flange to multifunction assembly whilst ensuring correct seating of the O ring ⑤ on the flange.

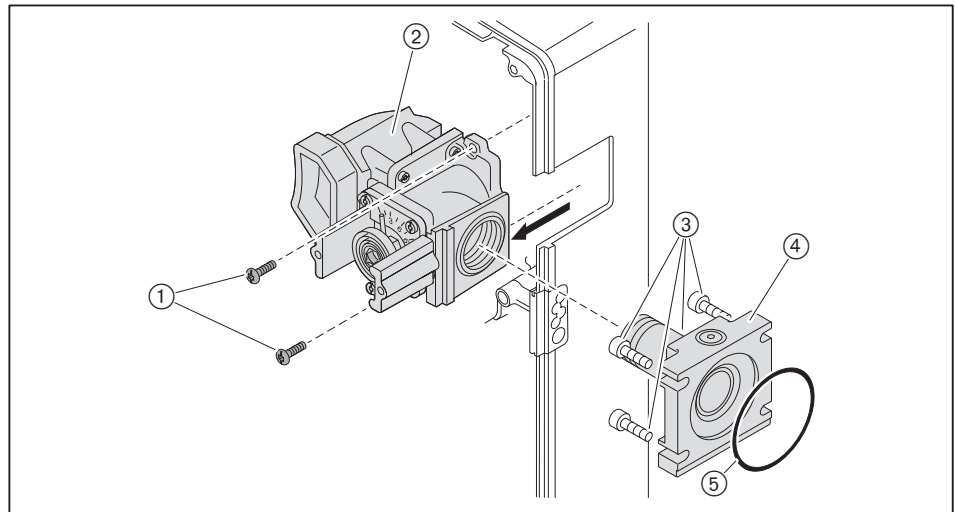

- ▶ Carry out soundness test [ch. 7.1.3].

9 Servicing

### 9.13 Removing and refitting air regulator

Observe notes on servicing [ch. 9.1].

#### Removing

- ▶ Remove bolts ①.
- ▶ Remove burner from heat exchanger [ch. 4.2].
- ▶ Remove actuator plug ⑥.
- ▶ Remove bolts ②.
- ▶ Remove intake housing ⑤.
- ▶ Remove bolts ④.
- ▶ Remove air regulator ③.

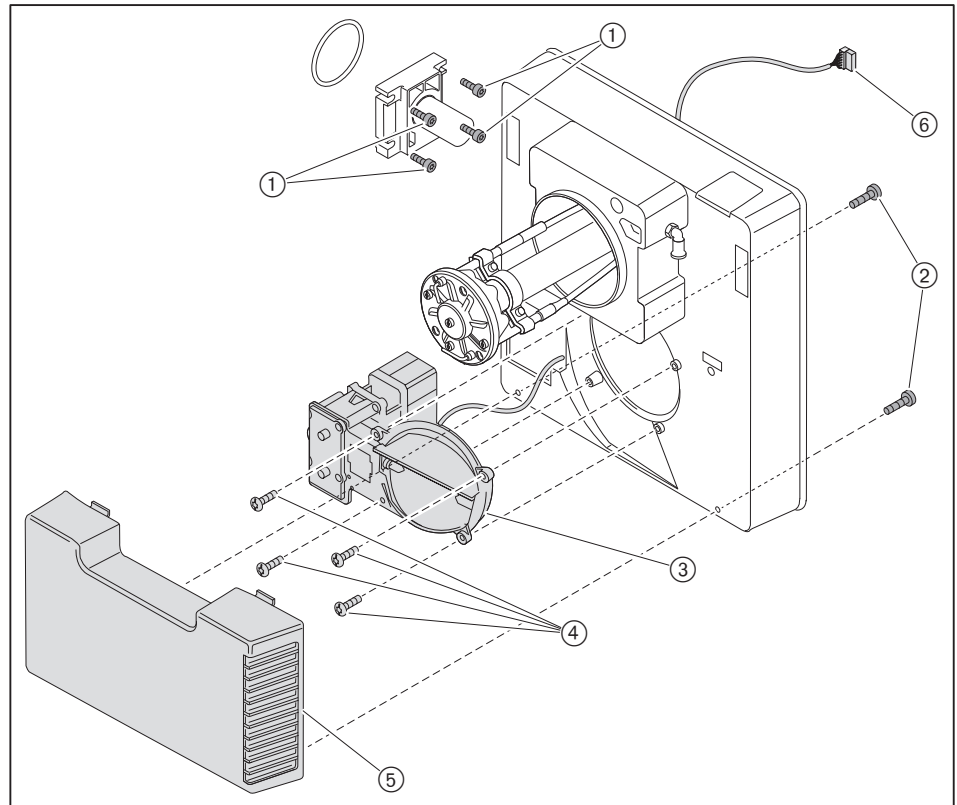

#### Refitting

- ▶ Refit air regulator in reverse order.
- ▶ Carry out soundness test [ch. 7.1.3].

### 9.14 Replacing coil on multifunction assembly

Observe notes on servicing [ch. 9.1].



Ensure correct voltage and solenoid number when replacing the solenoid coil.

- ▶ Undo screw ①.
- ▶ Remove cap ②.
- ▶ Replace solenoid coil ③.

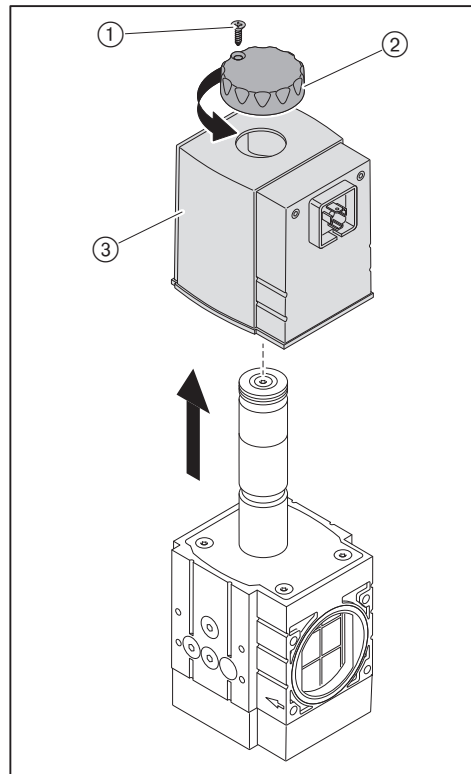

9 Servicing

**9.15 Replace breather plug of multifunction assembly**

Observe notes on servicing [ch. 9.1].

A breather plug with integrated filter is fitted to protect the breather orifice against soiling.

- Replace breather plug ①.

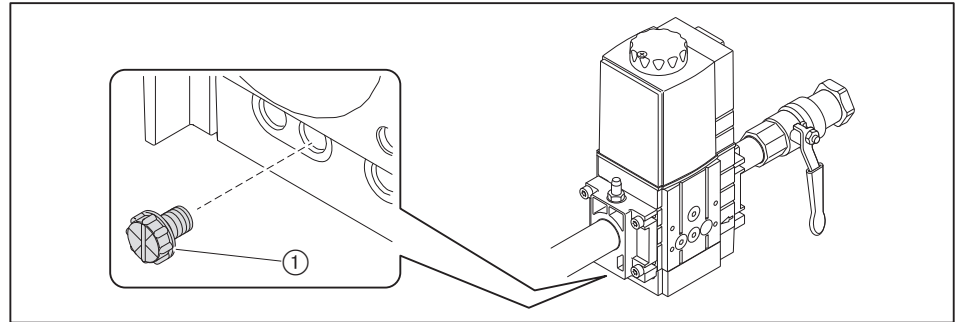

### 9.16 Removing and refitting filter insert of multifunction assembly

Observe notes on servicing [ch. 9.1].



Ensure no dirt enters the multifunction assembly when removing and replacing the filter insert.

#### Removing

- ▶ Remove screws ④.
- ▶ Remove cover ③.
- ▶ Remove filter insert ①.
- ▶ If necessary replace filter insert ① and seal ②.

#### Refitting

- ▶ Refit in reverse order ensuring correct alignment of filter ① and seal ②.

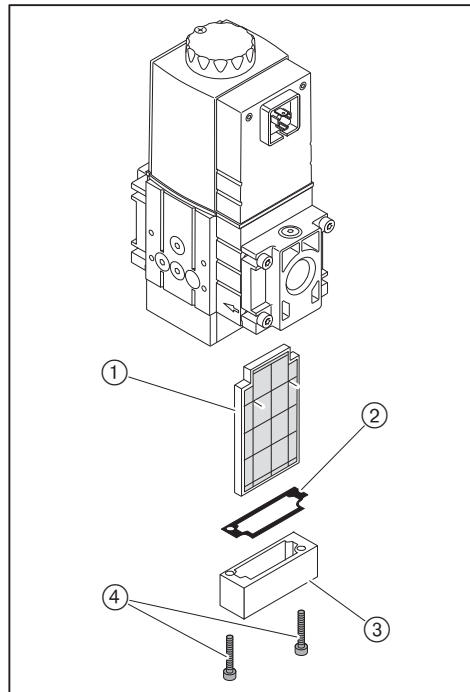

- ▶ Carry out soundness test [ch. 7.1.3].
- ▶ Vent gas valve train [ch. 7.1.4].

9 Servicing

9.17 Replacing the combustion manager

Observe notes on servicing [ch. 9.1].

- ▶ Unplug all plugs.
- ▶ Undo screws ①.
- ▶ Push combustion manager upwards and replace.

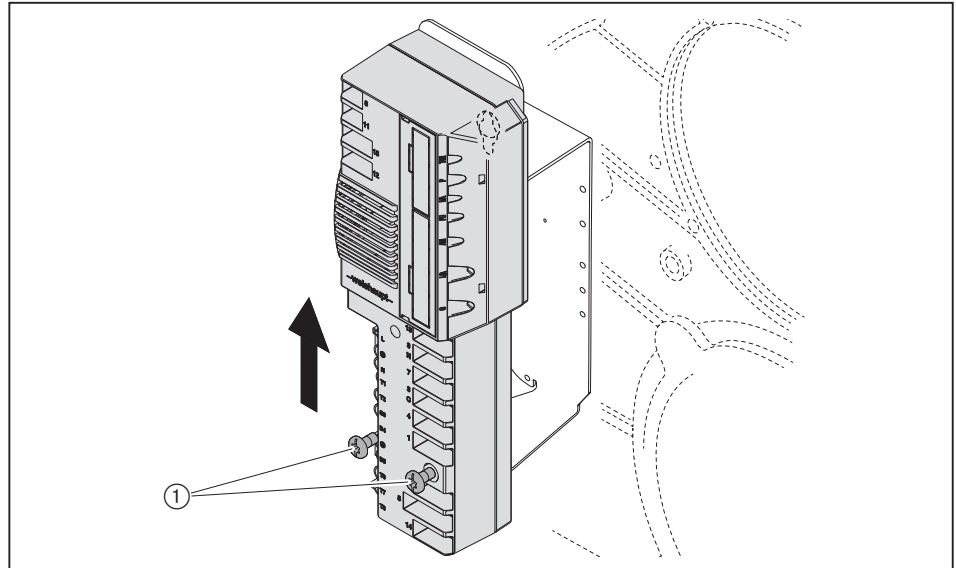

- ▶ Connect all plugs again.

Preset combustion manager

- ▶ Unplug bridging plug No. 7 on combustion manager.
- ▶ Switch on voltage supply.
- ✓ The unprogrammed condition of the combustion manager is indicated by a flashing display.  
The burner goes to lockout.

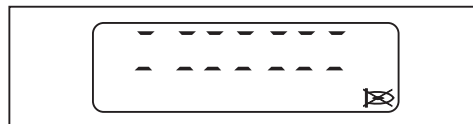

- ▶ Press [Enter].
- ✓ Burner has been reset.
- ✓ Combustion manager drives to Standby.





- ▶ Press [G] and [L/A] simultaneously.
- ✓ Combustion manager changes to access level.



- ▶ Press [+].
- ✓ Setting level (parameter E0) is displayed.



- ▶ Adopt value 0 (single fuel burner) and if necessary adjust using [Enter] and [-] key.
- ▶ Press [+].
- ✓ E1 is displayed.

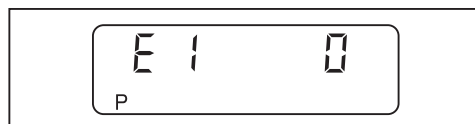

The value of parameter E1 can not be altered.

- 0: intermittent operation (Standard)
- 1: continuous operation

- ▶ Press [+].
- ✓ E2 is displayed.

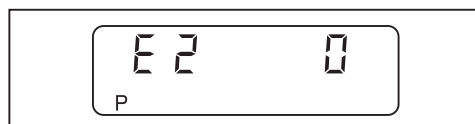

- ▶ Adopt value 0 (ionisation electrode) and if necessary adjust using [Enter] and [-] key.
- ▶ Press [+].
- ✓ E3 is displayed.

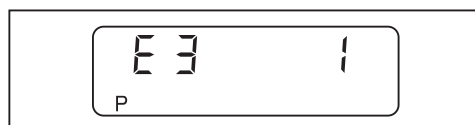

- ▶ Adopt value 1 (fan control) and if necessary adjust using [ENTER] and [-] or [+] key.
- ▶ Press [+].
- ✓ Combustion manager changes into the setting level for step points.

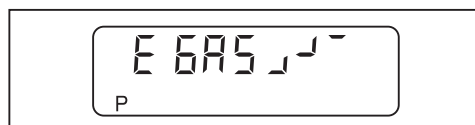

## 9 Servicing

- ▶ Determine the operating points from the sticker ①.
- ▶ Set the burner using these operating points and adjust [ch. 7.2].

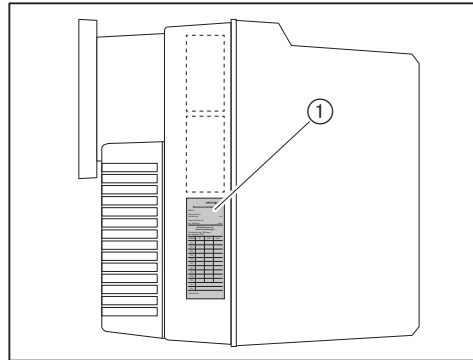

### Deactivate E-Parameters

Following commissioning, set parameter  $E$  to 0.

- ▶ Press [Enter] and [+] keys simultaneously for approx. 2 seconds.
- ✓ The parameter level is activated.
- ▶ Press [+].
- ▶ Press [Enter] key until parameter  $E$  is displayed.
- ▶ Set parameter  $E$  to 0 .
- ✓  $E$ -Parameters are not shown in the setting level.
- ▶ Press [Enter] key twice.
- ✓ The combustion manager returns to the operating level.

### 9.18 Replacing the fuse

Observe notes on servicing [ch. 9.1].

- ▶ Unplug connection plug from combustion manager.
- ▶ Replace fuse (T6.3H, IEC 127-2/5).

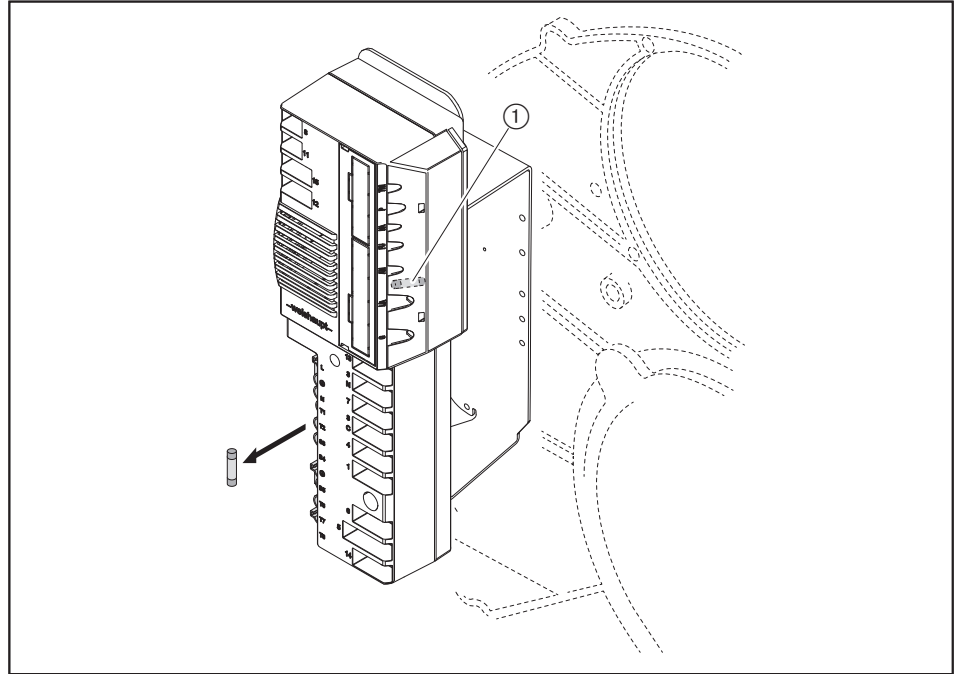

① Replacement fuse

10 Troubleshooting

10 Troubleshooting

10.1 Procedures for fault conditions

The combustion manager recognises irregularities of the burner and displays these on the display.

The following conditions can occur:

- Display off [ch. 10.1.1]
- Display OFF [ch. 10.1.2]
- Display flashes [ch. 10.1.3]

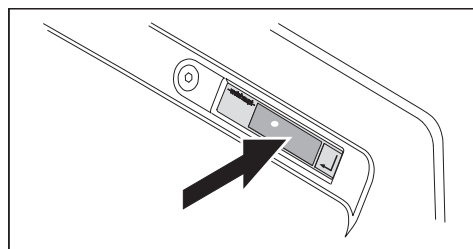

10.1.1 Display off

The following faults may be corrected by the operator:

Fault	Cause	Rectification
Burner not operating	External fuse has tripped <sup>(1)</sup>	▶ Check fuse.
	Heating switch is set to Off	▶ Switch on heating switch.
	Temperature limiter or pressure limiter on heat exchanger has triggered <sup>(1)</sup>	▶ Reset temperature limiter or pressure limiter on heat exchanger.
	Low water safety interlock on heat exchanger has triggered <sup>(1)</sup>	▶ Top up water. ▶ Reset low water safety interlock on heat exchanger.

<sup>(1)</sup> Notify your heating contractor or Weishaupt Customer Service if the problem occurs repeatedly.

10.1.2 Display OFF



The following faults may be corrected by the operator:

Fault	Cause	Rectification
Burner not operating	Temperature regulator or pressure regulator on heat exchanger has been set incorrectly	▶ Adjust temperature regulator or pressure regulator on heat exchanger.
	Boiler or heating circuit control is not functioning or has not been set correctly	▶ Check function and setting of boiler or heating circuit control.

### 10.1.3 Display flashes

A burner fault has occurred. The burner is in lockout. The error code is displayed flashing.

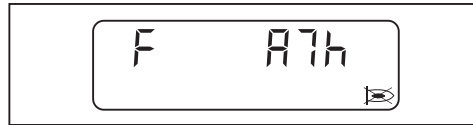

- ▶ Read error code, e. g. A7h.
- ▶ Rectify cause of fault [ch. 10.2].

#### Reset



#### Danger resulting from incorrect fault repair

Incorrect fault repair can cause damage to the equipment and injure personnel.

- ▶ Do not carry out more than 2 lockout resets successively.
- ▶ Faults must be rectified by qualified personnel.

- ▶ Press [Enter].
- ✓ Burner has been reset.

#### Fault memory

The last 9 faults are saved in the fault memory [ch. 6.2.2].

10 Troubleshooting

10.1.4 Detailed fault codes

Additional information, which breaks down the error in more detail, can be displayed by pressing a button.

The first detailed fault code and the second detailed fault code are only relevant for the following faults:

- 03h
- 18h
- 41h
- 65h

1. detailed error codes / operating status

► Press [+] key.

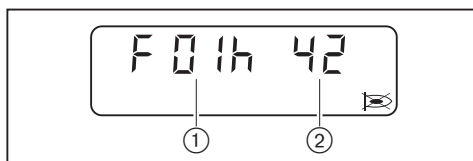

① First detailed fault code

② Operating status

Second detailed fault code

► Press [-] and [+] keys simultaneously.



Repetition counter

► Press key [G].

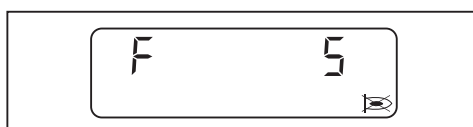

### 10.2 Rectifying faults

Faults must only be rectified by qualified personnel:

Fault codes	Cause	Rectification
01h ... 02h 05h ... 0bh 0Eh ... 10h 13h ... 15h 17h 19h ... 1Ch 1Eh 43h 45h 50h 56h A0h ACh b0h ... b2h b9h	Internal unit fault	<ul style="list-style-type: none"> <li>▶ Interrupt the voltage supply temporarily</li> <li>▶ Reset the burner, if fault reoccurs replace the combustion manager [ch. 9.17]</li> </ul>

Faults must only be rectified by qualified personnel:

Fault codes	Cause	Rectification
03h	First detailed fault code: 09h Ambient temperature too high	<ul style="list-style-type: none"> <li>▶ Interrupt the voltage supply temporarily</li> <li>▶ Check ambient temperature [ch. 3.4.3]</li> <li>▶ Reset the burner, if fault reoccurs replace the combustion manager [ch. 9.17]</li> </ul>
	Internal unit fault	<ul style="list-style-type: none"> <li>▶ Interrupt the voltage supply temporarily</li> <li>▶ Reset the burner, if fault reoccurs replace the combustion manager [ch. 9.17]</li> </ul>
04h	More than 5 resets in the last 15 minutes	<ul style="list-style-type: none"> <li>▶ Press and hold reset key for 5 seconds.</li> <li>✓ Display flashes.</li> <li>▶ Reset burner</li> </ul>
0Ch	Burner configuration incorrect	<ul style="list-style-type: none"> <li>▶ Check burner configuration</li> <li>▶ Check values in parameter level [ch. 6.2.3]</li> <li>▶ Check parameters E0 ... E3 [ch. 6.2.4]</li> </ul>
	Pre-purge phase less than 20 seconds (sum from parameters 60 and 61).	<ul style="list-style-type: none"> <li>▶ Increase pre-purge phase (only possible with VisionBox).</li> </ul>
11h	Low voltage	<ul style="list-style-type: none"> <li>▶ Check voltage supply</li> </ul>
12h	Voltage supply was temporarily interrupted	<ul style="list-style-type: none"> <li>▶ Check voltage supply</li> </ul>
16h	Communication with TWI interface (VisionBox) incorrect	<ul style="list-style-type: none"> <li>▶ Plug in and unplug participants on the TWI Bus only when de-energised</li> <li>▶ Reduce the number of participants on the TWI Bus</li> <li>▶ Reduce cable length</li> </ul>

10 Troubleshooting

Faults must only be rectified by qualified personnel:

Fault codes	Cause	Rectification
18h	Switch off via PC Software	–
	Second detailed fault code: A1h Invalid Bus address	▶ Check Bus address
	Second detailed fault code: A5h Configuration at output B4 incorrect	▶ Check configuration at output B4
	Second detailed fault code: A6h No keystrokes where made for 30 minutes in the setting mode	–
	Second detailed fault code: A7h Off function was activated	–
	Second detailed fault code: A8h No calibration values were stored in the EEPROM	–
	Second detailed fault code: A9h No Bus connection	▶ Check Bus connection
	Second detailed error code: AAh Communication to the expansion module failed	▶ Interrupt the voltage supply temporarily ▶ Check analogue module or Fieldbus module slot.
	Second detailed fault code: 01h ... 1Bh Internal unit fault	▶ Interrupt the voltage supply temporarily ▶ Reset the burner, if fault reoccurs replace the combustion manager [ch. 9.17]
	Second detailed fault code: E1h ... E7h Calibration values in EEPROM incorrect	–
	Second detailed fault code: EEh Communication to W-FM 25 failed	–
	Second detailed fault code: EFh Extension module to W-FM 25 not compatible	▶ Check version
	1dh	EMC interference
44h	Operating points were changed without approval	▶ Re-adjust burner
	Parameter E3 set incorrectly	▶ Check parameter E3 [ch. 6.2.4].
47h	Type of air actuator invalid	▶ Check parameter 34 (only possible with VisionBox).
	Type of gas actuator invalid	▶ Check parameter 35 (only possible with VisionBox).
48h	Plugs of actuators for gas and air mixed up	▶ Change over plugs
	Tolerance fault actuator	▶ Check freedom of movement of air damper and / or angle drive and gas butterfly valve ▶ Replace actuator
49h	Actuator does not drive to reference point correctly	▶ Check freedom of movement of air damper and / or angle drive and gas butterfly valve ▶ Replace actuator
53h	Insufficient gas, low gas pressure switch/ valve proving gas pressure switch	▶ Check gas connection pressure [ch. 7.1.5] ▶ Set gas pressure switch [ch. 7.3.1] ▶ Check gas pressure switch



Faults must only be rectified by qualified personnel:

Fault codes	Cause	Rectification
65h	First detailed fault code: 00h Tolerance fault air actuator, gas actuator	<ul style="list-style-type: none"> <li>▶ Check freedom of movement of air damper and / or angle drive</li> <li>▶ Check freedom of movement of gas butterfly valve</li> <li>▶ Replace actuator</li> </ul>
	First detailed fault code: 01h Tolerance fault air actuator or gas actuator	<ul style="list-style-type: none"> <li>▶ Check freedom of movement of air damper and / or angle drive</li> <li>▶ Check freedom of movement of gas butterfly valve</li> <li>▶ Replace actuator</li> </ul>
	First detailed fault code: 02h Tolerance fault gas actuator	<ul style="list-style-type: none"> <li>▶ Check freedom of movement of gas butterfly valve</li> <li>▶ Replace actuator</li> </ul>
	First detailed fault code: 03h Tolerance fault gas actuator	<ul style="list-style-type: none"> <li>▶ Check freedom of movement of gas butterfly valve</li> <li>▶ Replace actuator</li> </ul>
	First detailed fault code: 04h Tolerance fault air actuator	<ul style="list-style-type: none"> <li>▶ Check freedom of movement of air damper and / or angle drive</li> <li>▶ Replace actuator</li> </ul>
	First detailed fault code: 05h Tolerance fault air actuator	<ul style="list-style-type: none"> <li>▶ Check freedom of movement of air damper and / or angle drive</li> <li>▶ Replace actuator</li> </ul>
	First detailed fault code: 07h Time in setting mode run out Plugs of actuators for gas and air mixed up	<ul style="list-style-type: none"> <li>▶ Press key within 30 minutes in setting mode</li> <li>▶ Change over plugs</li> </ul>
A2h	Safety circuit is open	▶ Check safety circuit
A4h	Reverse voltage valve 1	▶ Check wiring to double solenoid valve
A5h	Reverse voltage valve 2	▶ Check wiring to double solenoid valve
A6h	Flame simulation/extraneous light	<ul style="list-style-type: none"> <li>▶ Find and eliminate extraneous light source</li> <li>▶ Check ionisation electrode</li> </ul>
A7h	No flame signal after safety time	<ul style="list-style-type: none"> <li>▶ Set ignition electrode [ch. 9.5]</li> <li>▶ Check the ignition unit and replace if necessary</li> <li>▶ Check solenoid valve coil and cable, replace if necessary</li> <li>▶ Check the ionisation electrode and cable, replace if necessary.</li> <li>▶ Check mixing pressure, if necessary reduce</li> <li>▶ Check burner setting</li> <li>▶ Replace combustion manager [ch. 9.17]</li> </ul>
A8h	Flame failure during operation	<ul style="list-style-type: none"> <li>▶ Check burner setting</li> <li>▶ Check the ionisation electrode, replace if necessary [ch. 9.5].</li> </ul>
A9h	Flame failure during stabilisation time	▶ see A7h
AAh	Switch contact of air pressure switch not in Standby	<ul style="list-style-type: none"> <li>▶ Check air pressure influences</li> <li>▶ Check air pressure switch setting [ch. 7.3.2]</li> <li>▶ Check air pressure switch and cable, replace if necessary</li> <li>▶ Replace combustion manager [ch. 9.17]</li> </ul>

## 10 Troubleshooting

Faults must only be rectified by qualified personnel:

Fault codes	Cause	Rectification
Abh	Air pressure switch does not react	<ul style="list-style-type: none"> <li>▶ Check air pressure switch setting [ch. 7.3.2]</li> <li>▶ Check hoses on air pressure switch</li> <li>▶ Check air pressure switch and cable, replace if necessary</li> <li>▶ Check burner motor and cable, replace if necessary [ch. 9.8]</li> </ul>
Adh	Insufficient gas low gas pressure switch	<ul style="list-style-type: none"> <li>▶ Check gas connection pressure [ch. 7.1.5]</li> <li>▶ Set gas pressure switch [ch. 7.3.1]</li> <li>▶ Check gas pressure switch</li> </ul>
AEh	Valve 1 leaking during valve proving	<ul style="list-style-type: none"> <li>▶ Check soundness of gas valve train [ch. 7.1.3]</li> <li>▶ Check setting and function of gas pressure switch [ch. 7.3.1]</li> <li>▶ Replace double gas valve</li> <li>▶ Check parameter E0 [ch. 6.2.4].</li> </ul>
AFh	Valve 2 leaking during valve proving	<ul style="list-style-type: none"> <li>▶ Check soundness of gas valve train [ch. 7.1.3]</li> <li>▶ Check setting and function of gas pressure switch [ch. 7.3.1]</li> <li>▶ Replace double gas valve</li> </ul>
b6h	Fault POC contact	<ul style="list-style-type: none"> <li>▶ Check POC contact</li> <li>▶ Check double gas valve (valve 1)</li> </ul>
bAh	Flame simulation/extraneous light at start-up	<ul style="list-style-type: none"> <li>▶ Find and eliminate extraneous light source</li> <li>▶ Check ionisation electrode</li> </ul>
bbh	Burner shutdown via contact X3:7 (plug No. 7)	–
CAh	Valve proving faulty	<ul style="list-style-type: none"> <li>▶ Check low gas pressure switch/valve proving gas pressure switch</li> <li>▶ Check double gas valve</li> </ul>
Cdh	No signal on input X3:15	<ul style="list-style-type: none"> <li>▶ Check wiring</li> </ul>
CEh	Bridging plug No. 15 is missing	<ul style="list-style-type: none"> <li>▶ Plug in bridging plug</li> </ul>
	High gas pressure switch does not react	<ul style="list-style-type: none"> <li>▶ Check gas connection pressure [ch. 7.1.5]</li> <li>▶ Set gas pressure switch</li> <li>▶ Check gas pressure switch</li> </ul>
CFh	No start release (X3:14)	<ul style="list-style-type: none"> <li>▶ Check start release</li> </ul>
d1h	Connection to actuator faulty	<ul style="list-style-type: none"> <li>▶ Rectify the fault using the following procedure:                             <ul style="list-style-type: none"> <li>▪ Interrupt voltage supply.</li> <li>▪ Plug in plug on combustion manager correctly</li> <li>▪ Fit W-FM cover [ch. 3.3.5].</li> </ul> </li> </ul>
	Parameter E0 not configured correctly	<ul style="list-style-type: none"> <li>▶ Check configuration of parameter E0 see [ch. 6.2.4].</li> </ul>
d2h	More than 5 resets in the past 15 minutes by remote reset (X3:14)	<ul style="list-style-type: none"> <li>▶ Rectify cause of fault</li> <li>▶ Reset via operating panel on burner.</li> <li>▶ Press and hold reset key for 5 seconds.</li> <li>✓ Display flashes.</li> <li>▶ Reset burner</li> </ul>
d4h	External voltage at operating signal X7:B5	<ul style="list-style-type: none"> <li>▶ Find and eliminate external voltage source</li> </ul>
	Internal unit fault	<ul style="list-style-type: none"> <li>▶ Interrupt the voltage supply temporarily</li> <li>▶ Reset the burner, if fault reoccurs replace the combustion manager [ch. 9.17]</li> </ul>

### 10.3 Operating problems

Faults must only be rectified by qualified personnel:

Observation	Cause	Rectification
Poor start behaviour of burner	Mixing pressure too high	▶ Reduce mixing pressure in ignition position
	Ignition electrode set incorrectly	▶ Set ignition electrode [ch. 9.5]
	Mixing head set incorrectly	▶ Set mixing head [ch. 9.4]
Combustion pulsating and/or burner booming	Mixing head set incorrectly	▶ Set mixing head [ch. 9.4]
	Incorrect combustion air quantity	▶ Adjust burner
Stability problems	Mixing pressure too high	▶ Decrease mixing pressure
No display at operating panel	Plug from operating panel not properly plugged in	▶ Plug in plug on combustion manager correctly
	Operating panel defective	▶ Replace operating panel

## 11 Technical documentation

## 11 Technical documentation

## 11.1 Program sequence

The exact operating status of the combustion manager can also be displayed.  
Activate operating status [ch. 6].

Operating phase	Operating status	Condition / function
F . .	00	Fault present
OFFUPr	01	Unprogrammed condition or programming not completed
OFF	02	Standby, no heat demand
1	03	Extraneous light check
2	04	Shutdown check air pressure switch
	05	Initialisation W-FM
	06	Waiting for start release / waiting time O <sub>2</sub> trim
	07	Internal sequence
3	08	Driving air damper actuator to pre-purge and gas butterfly valve actuator to ignition position
	09	Internal sequence
	10	Start burner motor
4	11	Waiting for air pressure
	12	Pre-purge
5	13	Internal sequence
	14	Driving air damper actuator to ignition position
6	15	Gas pressure check on low / valve proving gas pressure switch
	16	Ignition
7	17	First safety time - fuel release
	18	First safety time - flame detection
8	19	First stabilisation time
	20	Stop setting mode: P0 -A
	21	Second safety time
	22	Second stabilisation time
	23	End setting mode: P0 -B
9	24	Driving to partial load
10	25	Operation (load control is activated)
11	34	Valve proving - venting valve interspace
12	35	Valve proving - test time valve 1
	36	Internal sequence
13	37	Valve proving - filling valve interspace
14	38	Valve proving - test time valve 2
	39	Internal sequence
15	26	Internal sequence
	27	Driving to partial load
	28	Close fuel valves
	29	Internal sequence
	30	Start post burn time / post-purge
	31	Post-purge contact dependent (X3:14)
	32	Post burn time

Operating phase	Operating status	Condition / function
16 . . . .	33	Restart interlock
G L	40	Reference search actuator - air damper and gas butterfly valve
G	41	Test gas butterfly valve actuator 105°
G L	42	Drive to Standby position
	43	Internal sequence
OFFGd	44	Insufficient gas, low gas pressure switch (X3:14)
16 . . . .	45	Low gas programme
OFF S	46	Safety circuit open (X3:7)

11 Technical documentation

11.2 Conversion table unit of pressure

Bar	Pascal			
	Pa	hPa	kPa	MPa
0.1 mbar	10	0.1	0.01	0.00001
1 mbar	100	1	0.1	0.0001
10 mbar	1 000	10	1	0.001
100 mbar	10 000	100	10	0.01
1 bar	100 000	1 000	100	0.1
10 bar	1 000 000	10 000	1 000	1

### 11.3 Appliance categories

#### Labelling of forced-draught gas and dual fuel burners per EN 676

EN 676, "Forced draught burners for gaseous fuels", is used for the implementation of the basic requirements of the directive (EU) 2016/426.

EN 676 stipulate the following appliance categories for forced draught gas burners under Point 4.4.9:

I2R	for Natural Gas
I3R	for Liquid Petroleum Gas
II2R/3R	for Natural Gas / Liquid Petroleum Gas

The test gases listed under point 5.1.1, table 4 and the minimum test pressures determined and listed under point 5.1.2, table 5 are used to provide the evidence of service performance of the burner during type testing.

As -Weishaupt- gas and dual fuel burners fulfil this requirement completely, the appliance category, as well as the test gases used with the permissible connection pressure range, are listed on the name plate when labelling the burner to point 6.2. This clearly defines the suitability of the burner for use with second and third family gases.

On the basis of a type test report to ISO 17025 from an accredited test centre, the EU Type Testing Certificate to Directive (EU) 2016/426 also quotes the appliance category, the supply pressure and the country of destination.

EN 437, "Test gases - test pressures - appliance categories", describes the interrelationships and the special national characteristics relating to this subject in detail.

The following tables give an overview of the interrelationships between the R Categories and the nationally used appliance categories with their test gases and connection pressures.

11 Technical documentation

Alternative appliance category to I2R

Country of destination	Appliance category	Test gas	Connection pressure [mbar]
AT (Austria)	I <sub>2H</sub>	G 20	20
BE (Belgium)	I <sub>2E+</sub> , I <sub>2N</sub> , I <sub>2E(S)</sub> , I <sub>2E(R)</sub>	G 20	Pressure range 20↔25
CH (Switzerland)	I <sub>2H</sub>	G 20	20
CZ (Czech Republic)	I <sub>2H</sub>	G 20	20
DE (Germany)	I <sub>2E</sub> , I <sub>2N</sub> , I <sub>2ELL</sub>	G 20, G 25	20
DK (Denmark)	I <sub>2H</sub> , I <sub>2N</sub>	G 20	20
EE (Estonia)	I <sub>2H</sub>	G 20	20
ES (Spain)	I <sub>2H</sub> , I <sub>2N</sub>	G 20	20
FI (Finland)	I <sub>2H</sub>	G 20	20
FR (France)	I <sub>2E+</sub> , I <sub>2L</sub> , I <sub>2H</sub> , I <sub>2N</sub> , I <sub>2Esi</sub> , I <sub>2Er</sub>	G 20, G 25	Pressure range 20↔25
GB (United Kingdom)	I <sub>2H</sub>	G 20	20
GR (Greece)	I <sub>2H</sub> , I <sub>2N</sub>	G 20	20
HR (Croatia)	I <sub>2H</sub>	G 20	20
HU (Hungary)	I <sub>2H</sub> , I <sub>2HS</sub>	G 20, G 25.1	20
IE (Ireland)	I <sub>2H</sub>	G 20	20
IT (Italy)	I <sub>2H</sub> , I <sub>2HM</sub>	G 20, G 230	20
LT (Lithuania)	I <sub>2H</sub>	G 20	20
LV (Latvia)	I <sub>2H</sub>	G 20	20
NL (Netherlands)	I <sub>2EK</sub> , I <sub>2N</sub>	G 25.3, G 20	20
NO (Norway)	I <sub>2H</sub>	G 20	20
PL (Poland)	I <sub>2E</sub> , I <sub>2N</sub> , I <sub>2ELw</sub> , I <sub>2ELs</sub> , I <sub>2ELn</sub> , I <sub>2ELwLs</sub> , I <sub>2ELwLsLn</sub>	G 20, G 27, G 2.300, G 2.350	20
PT (Portugal)	I <sub>2H</sub> , I <sub>2N</sub>	G 20	20
RO (Romania)	I <sub>2H</sub> , I <sub>2L</sub> , I <sub>2E</sub>	G 20	20 / 25
SE (Sweden)	I <sub>2H</sub>	G 20	20
SI (Slovenia)	I <sub>2H</sub> , I <sub>2N</sub>	G 20	20
SK (Slovakia)	I <sub>2H</sub>	G 20	20
TR (Turkey)	I <sub>2H</sub>	G 20	20



## Alternative appliance category to I3R

Country of destination	Appliance category	Test gas	Connection pressure [mbar]
AT (Austria)	I <sub>3B/P</sub> , I <sub>3P</sub>	G 30, G 31	30 / 50
BE (Belgium)	I <sub>3+</sub> , I <sub>3P</sub> , I <sub>3B</sub> , I <sub>3B/P</sub>	G 30, G 31	Pressure range 28-30↔37 50
CH (Switzerland)	I <sub>3B/P</sub> , I <sub>3+</sub> , I <sub>3P</sub>	G 30, G 31	Pressure range 28-30↔37 50
CY (Cyprus)	I <sub>3B/P</sub> , I <sub>3+</sub> , I <sub>3B</sub>	G 30, G 31	Pressure range 28-30↔37 Pressure range 50↔67
CZ (Czech Republic)	I <sub>3B/P</sub> , I <sub>3+</sub> , I <sub>3P</sub>	G 30, G 31	Pressure range 28-30↔37 50
DE (Germany)	I <sub>3B/P</sub> , I <sub>3P</sub>	G 30, G 31	30/50
DK (Denmark)	I <sub>3B/P</sub>	G 30, G 31	30
EE (Estonia)	I <sub>3B/P</sub>	G 30, G 31	30
ES (Spain)	I <sub>3+</sub> , I <sub>3P</sub> , I <sub>3B</sub>	G 30, G 31	Pressure range 28-30↔37 50
FI (Finland)	I <sub>3B/P</sub>	G 30, G 31	28-30
FR (France)	I <sub>3+</sub> , I <sub>3P</sub> , I <sub>3B</sub> , I <sub>3B/P</sub>	G 30, G 31	Pressure range 28-30↔37 50 Pressure range 112↔148
GB (United Kingdom)	I <sub>3+</sub> , I <sub>3P</sub> , I <sub>3B</sub> , I <sub>3B/P</sub>	G 30, G 31	Pressure range 28-30↔37 50
GR (Greece)	I <sub>3B/P</sub> , I <sub>3+</sub> , I <sub>3P</sub> , I <sub>3B</sub>	G 30, G 31	Pressure range 28-30↔37 50
HR (Croatia)	I <sub>3B/P</sub> , I <sub>3P</sub>	G 30, G 31	30 / 37
HU (Hungary)	I <sub>3B/P</sub> , I <sub>3P</sub> , I <sub>3B</sub>	G 30, G 31	30
IE (Ireland)	I <sub>3+</sub> , I <sub>3P</sub> , I <sub>3B</sub>	G 30, G 31	Pressure range 28-30↔37
IT (Italy)	I <sub>3B/P</sub> , I <sub>3+</sub> , I <sub>3P</sub>	G 30, G 31	Pressure range 28-30↔37
LT (Lithuania)	I <sub>3B/P</sub> , I <sub>3+</sub> , I <sub>3P</sub>	G 30, G 31	Pressure range 28-30↔37
NL (Netherlands)	I <sub>3B/P</sub> , I <sub>3P</sub>	G 30, G 31	30 / 37 / 50
NO (Norway)	I <sub>3B/P</sub>	G 30, G 31	30
PL (Poland)	I <sub>3B/P</sub> , I <sub>3P</sub> , I <sub>3P(B/P)</sub>	G 30, G 31	30 / 37
PT (Portugal)	I <sub>3+</sub> , I <sub>3P</sub> , I <sub>3B</sub>	G 30, G 31	Pressure range 28-30↔37 Pressure range 50↔67
RO (Romania)	I <sub>3B/P</sub> , I <sub>3P</sub>	G 30, G 31	30
SE (Sweden)	I <sub>3B/P</sub>	G 30, G 31	30
SI (Slovenia)	I <sub>3B/P</sub> , I <sub>3+</sub> , I <sub>3P</sub>	G 30, G 31	Pressure range 28-30↔37
TR (Turkey)	I <sub>3B/P</sub> , I <sub>3+</sub>	G 30, G 31	Pressure range 28-30↔37

11 Technical documentation

Alternative appliance category to II2R/3R

Country of destination	Appliance category	Test gas	Connection pressure [mbar]	Test gas	Connection pressure [mbar]
AT (Austria)	II <sub>2</sub> H3B/P, II <sub>2</sub> H3P	G 20	20	G 30, G 31	30 / 50
BE (Belgium)	II <sub>2</sub> E+3P, II <sub>2</sub> E+3+, II <sub>2</sub> E+3B, II <sub>2</sub> E(S)3P, II <sub>2</sub> E(R)3P	G 20	Pressure range 20≤25	G 30, G 31	Pressure range 28-30≤37 50
CH (Switzerland)	II <sub>2</sub> H3B/P, II <sub>2</sub> H3+, II <sub>2</sub> H3P	G 20	20	G 30, G 31	Pressure range 28-30≤37 50
CY (Cyprus)	II <sub>2</sub> H3B/P, II <sub>2</sub> H3+	G 20	20	G 30, G 31	Pressure range 28-30≤37 Pressure range 50≤67
CZ (Czech Republic)	II <sub>2</sub> H3B/P, II <sub>2</sub> H3+, II <sub>2</sub> H3P	G 20	20	G 30, G 31	Pressure range 50≤67
DE (Germany)	II <sub>2</sub> E3B/P, II <sub>2</sub> ELL3B/P, II <sub>2</sub> ELL3P, II <sub>2</sub> E3P	G 20, G 25	20	G 30, G 31	30 / 50
DK (Denmark)	II <sub>1a2</sub> H, II <sub>2</sub> H3B/P	G 20	20	G 30, G 31	30
EE (Estonia)	II <sub>2</sub> H3B/P	G 20	20	G 30	30
ES (Spain)	II <sub>2</sub> H3P, II <sub>2</sub> H3+	G 20	20	G 30, G 31	Pressure range 28-30≤37 50
FI (Finland)	II <sub>2</sub> H3B/P	G 20	20	G 30, G 31	28-30
FR (France)	II <sub>2</sub> E+3+, II <sub>2</sub> E+3P, II <sub>2</sub> E+3B/P, II <sub>2</sub> L3P, II <sub>2</sub> H3P, II <sub>2</sub> Esi3+, II <sub>2</sub> Er3+, II <sub>2</sub> Esi3P, II <sub>2</sub> Er3P	G 20, G 25	Pressure range 20≤25	G 30, G 31	Pressure range 50≤67 Pressure range 112≤148
GB (United Kingdom)	II <sub>2</sub> H3+, II <sub>2</sub> H3P	G 20	20	G 30, G 31	Pressure range 28-30≤37 50
GR (Greece)	II <sub>2</sub> H3B/P, II <sub>2</sub> H3+, II <sub>2</sub> H3P	G 20	20	G 30, G 31	Pressure range 28-30≤37 50
HR (Croatia)	II <sub>2</sub> H3B/P, II <sub>2</sub> H3P	G 20	20	G 30, G 31	30 / 37
IE (Ireland)	II <sub>2</sub> H3+, II <sub>2</sub> H3P	G 20	20	G 30, G 31	Pressure range 28-30≤37
IT (Italy)	II <sub>1a2</sub> H, II <sub>2</sub> H3B/P, II <sub>2</sub> H3+, II <sub>2</sub> H3P, II <sub>2</sub> HM3+, II <sub>2</sub> HM3B/P, II <sub>2</sub> HM3P	G 20, G 230	20	G 30, G 31	Pressure range 28-30≤37
LT (Lithuania)	II <sub>2</sub> H3B/P, II <sub>2</sub> H3+, II <sub>2</sub> H3P	G 20	20	G 30, G 31	Pressure range 28-30≤37
NL (The Netherlands)	II <sub>2</sub> EK3B/P	G 25	20	G 31	30 / 37 / 50
NO (Norway)	II <sub>2</sub> H3B/P	G 20	20	G 30, G 31	30
PL (Poland)	II <sub>2</sub> E3B/P, II <sub>2</sub> E3P, II <sub>2</sub> E3P(B/P), II <sub>2</sub> ELs3B/P, II <sub>2</sub> ELs3P, II <sub>2</sub> HM3B/P, II <sub>2</sub> ELwLs3P, II <sub>2</sub> ELwLs3P(B/P), II <sub>2</sub> ELwLsLn3P(B/P)	G 20, G 27, G 2.300, G 2.350	20	G 30, G 31	30 / 37
PT (Portugal)	II <sub>2</sub> H3+, II <sub>2</sub> H3P	G 20	20	G 30, G 31	Pressure range 28-30≤37 Pressure range 50≤67

Country of destination	Appliance category	Test gas	Connection pressure [mbar]	Test gas	Connection pressure [mbar]
RO (Romania)	II <sub>2H3B/P</sub> , II <sub>2H3P</sub> , II <sub>2L3P</sub> , II <sub>2E3B/P</sub> , II <sub>2L3B/P</sub>	G 20	20 / 25	G 30, G 31	30
SE (Sweden)	II <sub>1a2H</sub> , II <sub>2H3B/P</sub>	G 20	20	G 30, G 31	30
SI (Slovenia)	II <sub>2H3B/P</sub> , II <sub>2H3+</sub> , II <sub>2H3P</sub>	G 20	20	G 30, G 31	Pressure range 28-30↔37
SK (Slovakia)	II <sub>2H3B/P</sub> , II <sub>2H3+</sub> , II <sub>2H3P</sub>	G 20	20	G 30, G 31	Pressure range 28-30↔37 50
TR (Turkey)	II <sub>2H3B/P</sub> , II <sub>2H3+</sub>	G 20	20	G 30, G 31	Pressure range 30↔37

## 12 Project planning

### 12.1 Continuous running fan or post-purge

---



#### **Fire hazard due to failure of the combustion air fan**

Failure of the combustion air fan (e.g. due to a power failure or defective motor) during operation with continuous running fan or increased post-purge may result in back radiation or hot flue gases flowing back into the burner housing. This could cause a fire.

If fail-safe continuous ventilation or post-purge is required, take appropriate measures, such as:

- ▶ installing compressed air flushing on site with:
    - sufficiently large compressed air tank
    - normally open compressed air valve
-

### 12.2 Additional requirements

Additional requirements for burner for liquid and gaseous fuels in accordance with EN 676:

- the pressure equipment operates in accordance with the Pressure Equipment Directive 2014/68/EU
- as a component of an industrial thermo-processing system to EN ISO 13577-2
- on steam and hot-water water-tube boilers to EN 12952-8

2014/68/EU	EN ISO 13577-2	EN 12952-8	Components	Requirement
X			Burner control, combustion manager	Designed for continuous operation greater than 1200 kW
		X	Flame monitor, flame sensor	self-checking
X			Control device air/fuel ratio	EN 12067-2
X	X	X	Air monitoring device	Min. air pressure switch to EN 1854
X	X	X	Monitoring device minimum fuel pressure	Low gas pressure switch to EN 1854
X	X	X	Monitoring device maximum fuel pressure	High gas pressure switch to EN 1854
X	X	X	Valve monitoring system, valve proving gas pressure switch	EN 1643
X	X	X	Gas pressure regulator	EN 88, EN 334
X	X	X	Automatic safety shut off valves (PED: for aggressive media)	2 x Group A, EN 161
	X		Manual shut off device for all fuels	Ball valve
	X		Safety devices for safe operation	Connected to the input of the combustion manager in the closed circuit current principle
		X	Electrical equipment	EN 50156

13 Spares

13 Spares

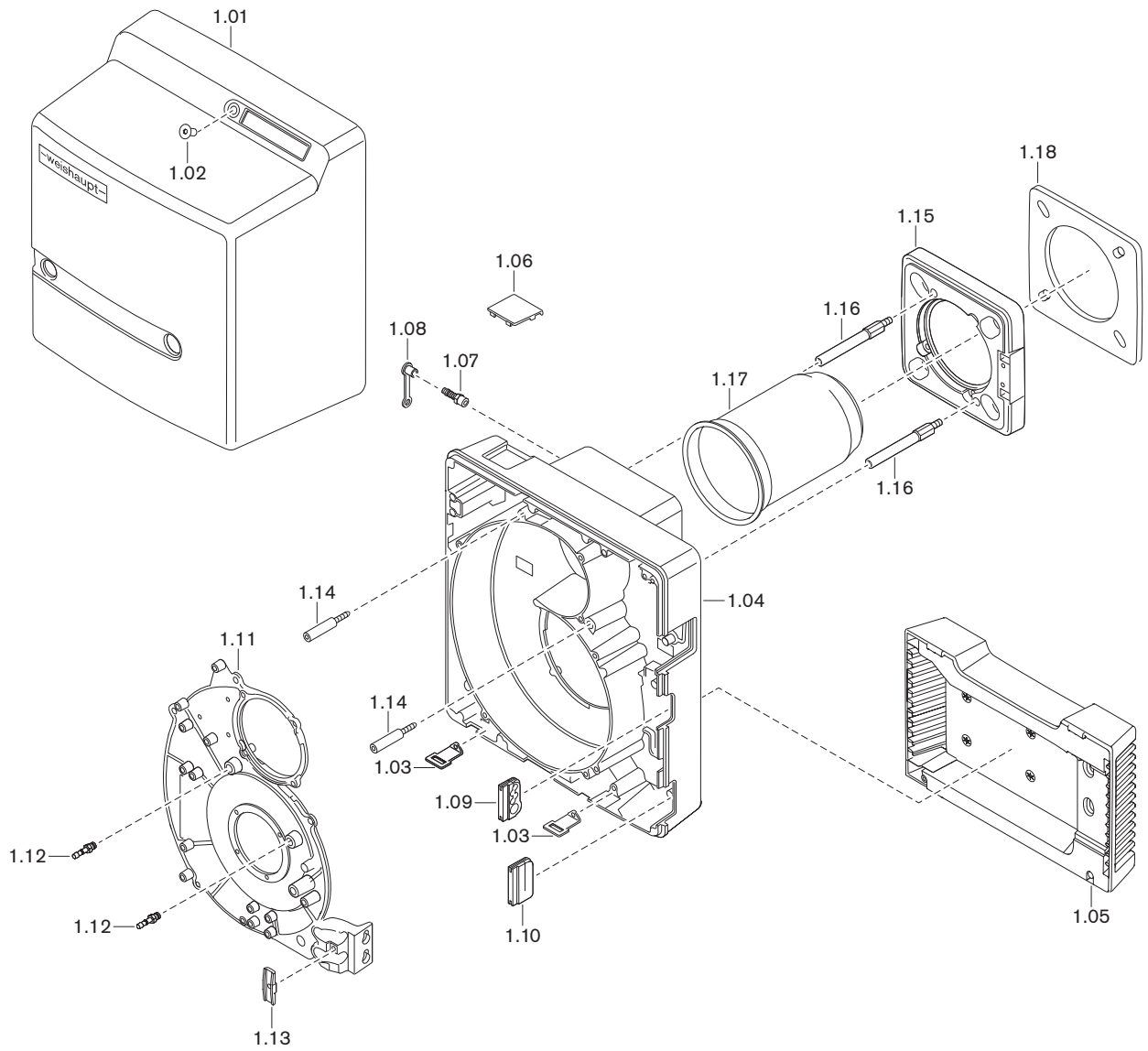

Pos.	Description	Order No.
1.01	Cover	232 210 01 112
1.02	Screw M8 x 16 ISO 10642	404 412
1.03	Mounting bracket for cover	241 400 01 207
1.04	Burner housing	241 210 01 012
1.05	Intake housing complete	241 210 01 082
	– Screw 4 x 30 Torx-Plus	409 325
1.06	View port on hours counter cover	241 210 01 197
1.07	Threaded socket R $\frac{1}{8}$ GES6	453 017
1.08	Protective cap DN 6 SELF 50/2 CF	232 300 01 047
1.09	Grommet for connection cable	241 200 01 247
1.10	Grommet	241 400 01 177
1.11	Housing cover	241 210 01 227
1.12	Threaded socket R $\frac{1}{8}$ GES4	453 004
1.13	Bracket for cable	241 400 01 367
1.14	Screw M8 burner housing	241 310 01 257
1.15	Burner flange	241 210 01 057
	– Screw ISO 4762 M8 x 30- 8.8	402 517
	– Washer 8.4 DIN 433	430 504
1.16	Stay bolt for burner flange	241 310 01 247
1.17	Flame tube WG20-C	
	– Standard	232 210 14 122
	– extended by 100 mm*	230 210 14 012
	– extended by 200 mm*	230 210 14 022
	– extended by 300 mm*	230 210 14 032
1.18	Flange gasket	241 210 01 107

\* Only in conjunction with combustion head extension.

13 Spares

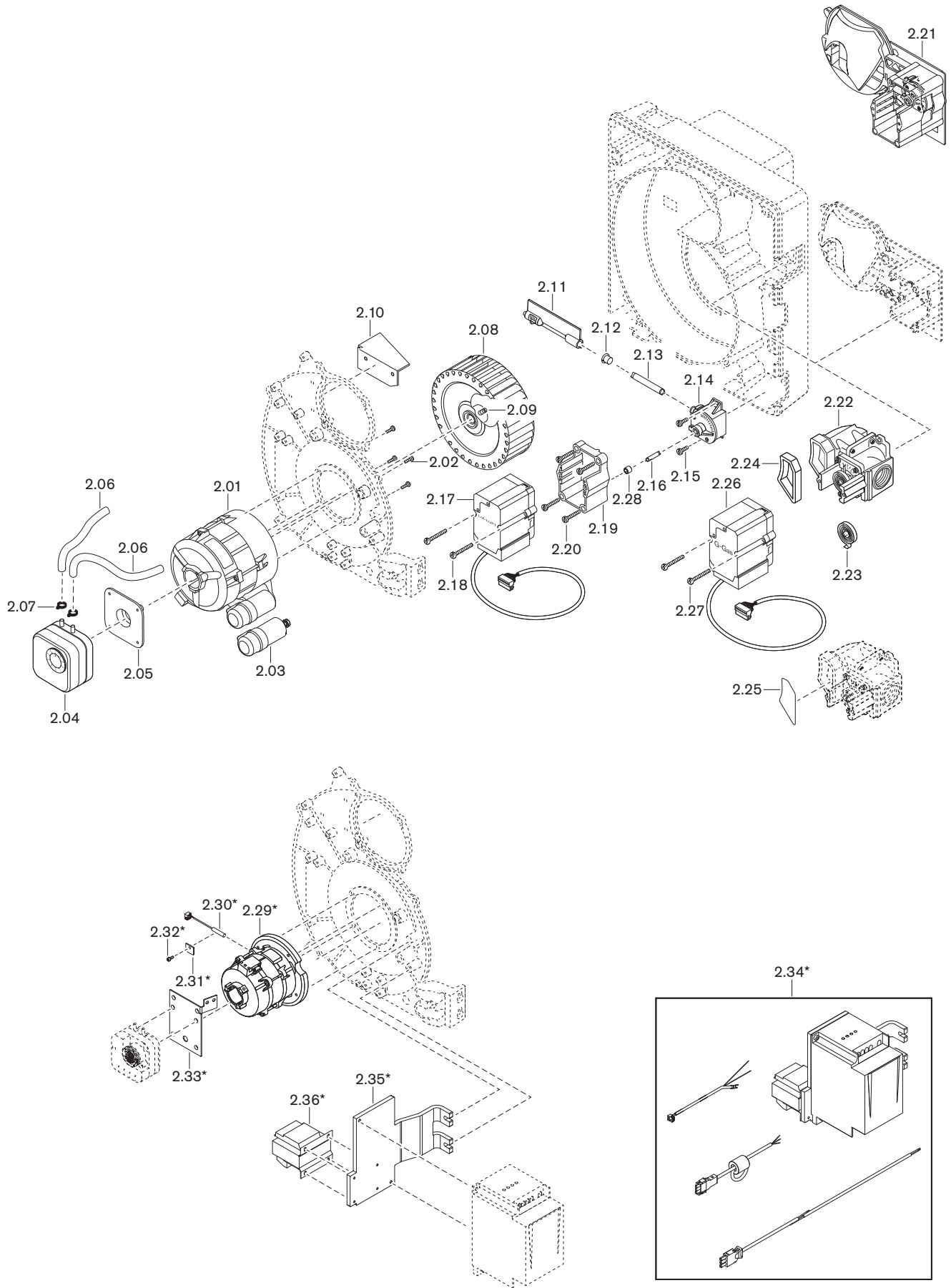



Pos.	Description	Order No.
2.01	Motor ECK04/S-2 230V 50Hz with cable	230 210 07 012
2.02	Screw M5 x 12	409 278
2.03	Capacitor set	713 476
2.04	Pressure switch LGW 10 A2 1 - 10 mbar	691 370
2.05	Connection flange for LGW	605 243
2.06	Hose 4.0 x 1.75 190 mm	232 050 24 057
2.07	Hose clamp 7.5	790 218
2.08	Fan wheel TLR-S 160 x 61.6-L-E S1 50 Hz	241 210 08 032
2.09	Grub screw M8 x 8 w. an. cutter	420 550
2.10	Air guide	232 210 01 147
2.11	Air damper complete	241 210 02 022
2.12	Bearing for air damper shaft	241 110 02 107
2.13	Shaft air damper - angle drive	241 210 02 057
2.14	Angle drive	241 110 02 062
2.15	Screw 4 x 12 Torx-Plus Remform	409 320
2.16	Shaft angle drive - actuator	241 400 02 157
2.17	Air actuator STE 4.5 24 V	651 103
2.18	Screw 4 x 35 Combi-Torx-Plus Remform	409 355
2.19	Frame for actuator	241 210 02 037
2.20	Screw 4 x 30 Torx-Plus Delta PT	409 325
2.21	Air regulator spring 2	241 210 02 072
2.22	Gas butterfly valve	232 210 25 020
2.23	Spring 2	241 400 02 167
2.24	Seal connection channel	232 210 25 087
2.25	Blanking plate valve proving	232 210 26 172
2.26	Gas actuator STE 4.5 24 V	651 101
2.27	Screw M4 x 30 Torx-Plus metric	409 245
2.28	Guide sleeve	241 400 02 207
2.29	Motor W-PM04/S-4*	232 210 08 022
	– Motor W-PM04/S-4 *	652 163
	– Intermediate motor flange GD-AISi9Cu3*	232 110 01 157
	– Screw M4 x 10 Torx-Plus 20IP metr.*	409 323
2.30	VSD sensor KJ1.5 motor W-PM63*	230 310 12 782
2.31	Clamping piece 2 x 17 x 20*	251 303 14 087
2.32	Screw M4 x 8 Precode*	232 110 08 027
2.33	Bracket for LGW*	232 110 24 057
2.34	Frequency convertor parameterised 230V*	232 210 12 072
2.35	Frequency convertor bracket*	232 110 12 047
2.36	Choke coil 4.8 mH for frequency convertor*	710 607

\* Only in conjunction with variable speed drive.

13 Spares

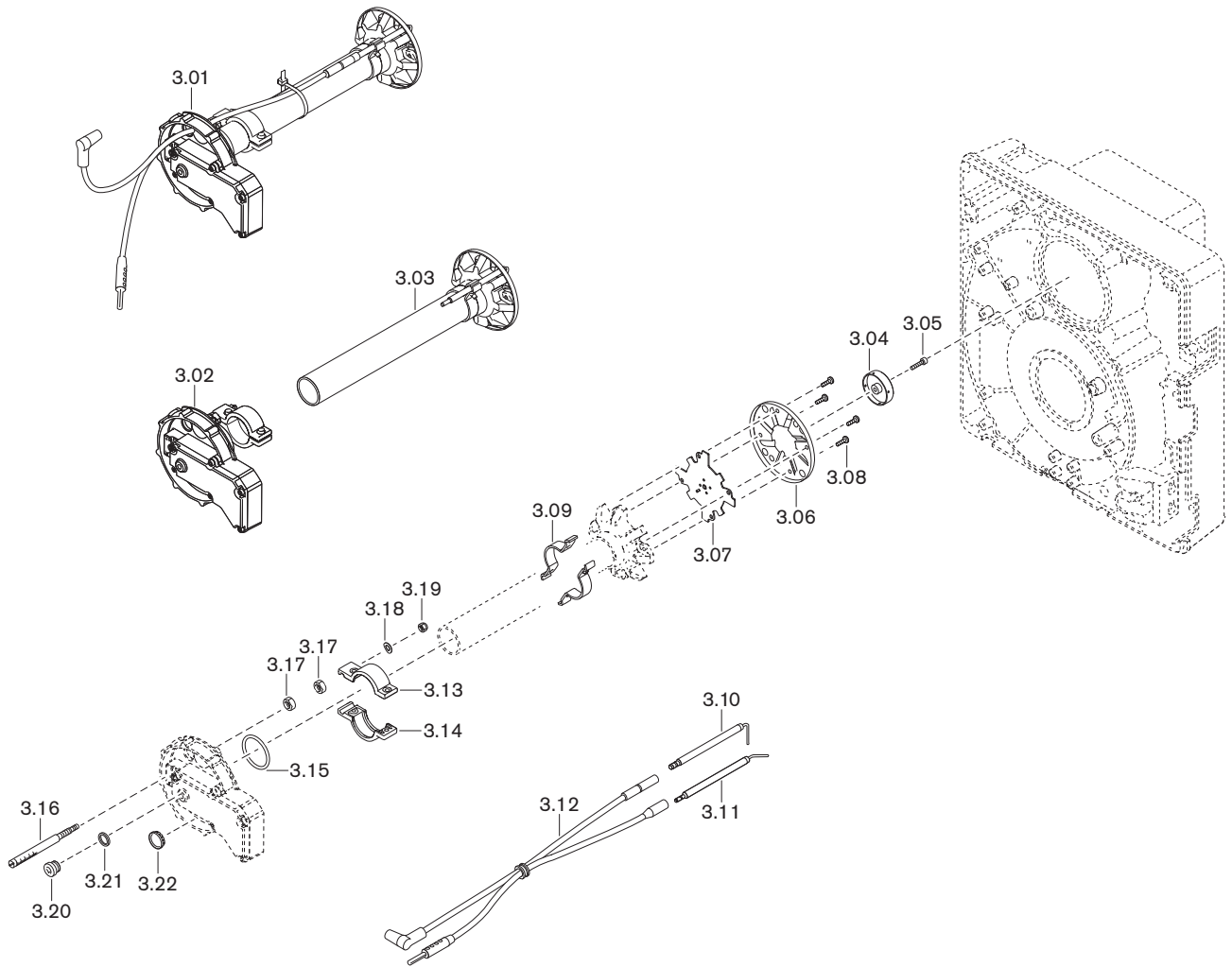

Pos.	Description	Order No.
3.01	Mixing head WG20N/1-C cpl. (Natural Gas)	
	– Standard	232 210 14 052
	– extended by 100 mm*	230 210 14 072
	– extended by 200 mm*	230 210 14 082
	– extended by 300 mm*	230 210 14 092
	Mixing head WG20F/1-C cpl. (LPG)	
	– Standard	233 210 14 012
	– extended by 100 mm*	230 210 14 132
	– extended by 200 mm*	230 210 14 142
	– extended by 300 mm*	230 210 14 152
3.02	Lock housing complete	232 210 14 022
3.03	Mixing tube WG20N/1-C cpl. (Natural Gas)	
	Ø internal 32 mm	
	– Standard	232 210 14 082
	– extended by 100 mm*	230 210 14 042
	– extended by 200 mm*	230 210 14 052
	– extended by 300 mm*	230 210 14 062
	Mixing tube WG20F/1-C cpl. (LPG)	
	Ø internal 18 mm	
	– Standard	233 210 14 022
	– extended by 100 mm*	230 210 14 102
	– extended by 200 mm*	230 210 14 112
	– extended by 300 mm*	230 210 14 122
3.04	Nozzle element	232 200 14 467
3.05	Screw M4 x 16 Torx-Plus 20IP	409 224
3.06	Diffuser 36 x 95	232 200 14 417
3.07	Nozzle insert	232 200 14 397
3.08	Screw M4 x 8 Torx-Plus 20IP	409 235
3.09	Bracket for electrodes	232 200 14 437
3.10	Ignition electrode isolator 6 x 80	232 200 14 217
3.11	Sensor electrode	232 100 14 207
3.12	Ignition and sensor cable	
	– 380 mm (Standard)	232 110 11 032
	– 480mm (for 100 mm extension)*	230 110 11 082
	– 600mm (for 200 mm extension)*	232 310 11 042
	– 700mm (for 300 mm extension)*	232 400 11 042
3.13	Carrier	232 200 14 037
3.14	Carrier	232 200 14 047
3.15	O ring 32 x 3 NBR70 ISO 3601	445 095
3.16	Adjusting screw	232 210 14 047
3.17	Hexagonal nut M8 left ISO 4032 -8	411 413
3.18	Spring washer A5 DIN 137	431 613
3.19	Hexagonal nut M5 DIN 985	411 203
3.20	Screw G <sup>1</sup> / <sub>8</sub> A DIN 908	409 004
3.21	Sealing ring 10 x 13.5 x 1.5 DIN 7603	441 033
3.22	View port glass	241 400 01 377

\* Only in conjunction with combustion head extension.

13 Spares

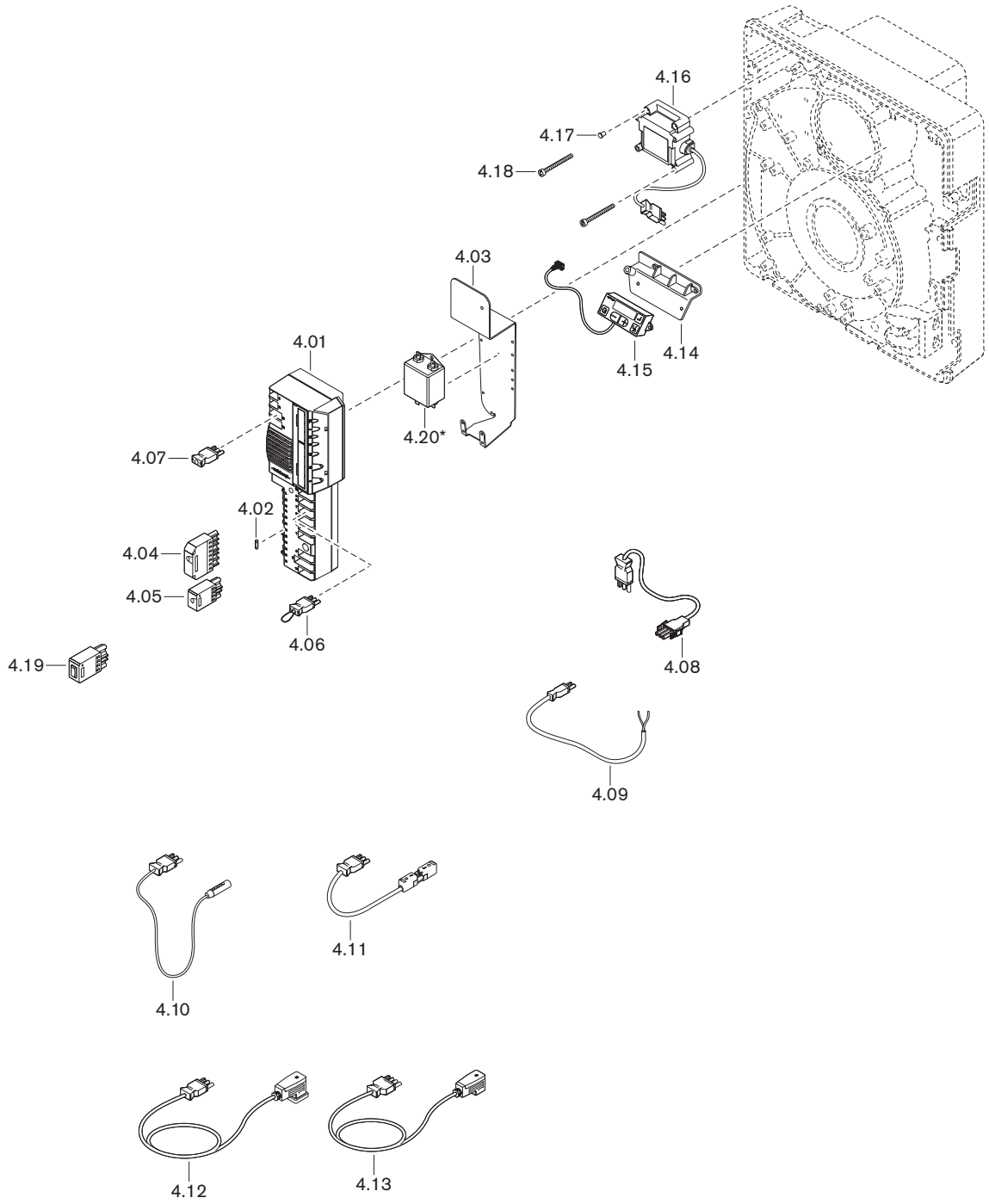

Pos.	Description	Order No.
4.01	Combustion manager W-FM25 / 230 V	
	– intermittent operation with O <sub>2</sub> trim	600 491
	– Continuous operation with O <sub>2</sub> trim (PO-O2)	600 489
4.02	Micro fuse T6.3H, IEC 127-2/5	483 011 22 457
4.03	Bracket without carrier rail	232 110 12 017
4.04	Plug unit ST18/7	716 549
4.05	Plug unit ST18/4	716 546
4.06	Intermediate plug No. 7	241 400 12 042
4.07	Intermediate plug No. 15	232 110 12 082
4.08	Plug cable No. 3 motor	241 050 12 062
4.09	Plug cable No.11 air pressure switch	232 110 12 032
4.10	Ionisation cable No. 13	232 310 12 012
4.11	Plug cable No. 14 remote reset	230 110 12 362
4.12	Plug cable No.12 gas pressure switch	232 050 12 022
4.13	Plug cable No. 5 W-FM, DMV	232 400 12 012
4.14	Fixing bracket	241 400 12 017
4.15	ABE for W-FM20 / 25 with 0.58 m cable	600 481
4.16	Ignition unit W-ZG01 230V 100VA Termal	603 201
4.17	Closing plug for ignition unit	603 224
4.18	Screw M4 x 42 Combi-Torx-Plus 20IP	409 260
4.19	Plug-in switch ST18/4	130 103 15 012
4.20	Mains filter*	710 611

\* Only in conjunction for variable speed drive with W-PM motor.

13 Spares

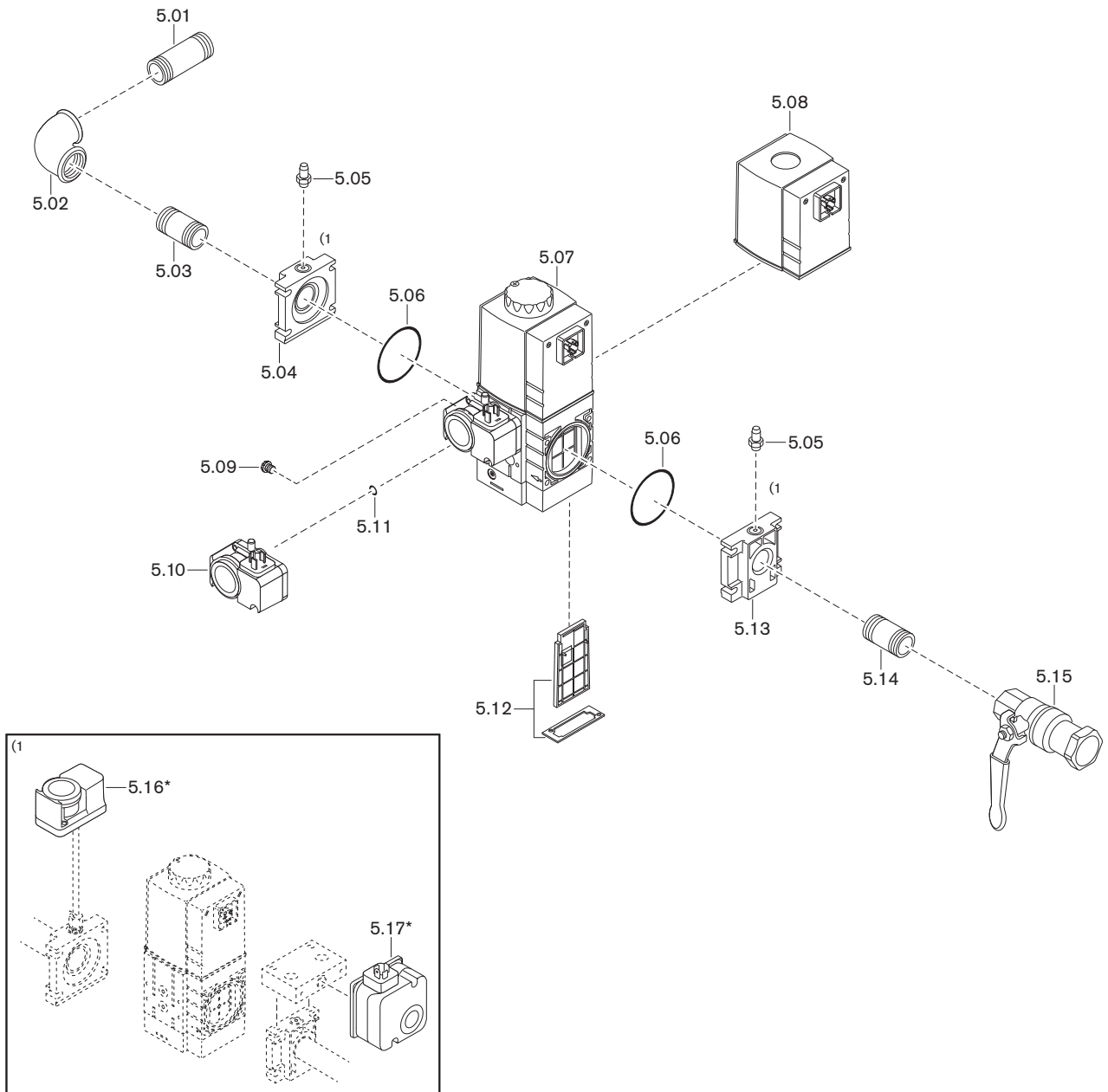

Pos.	Description	Order No.
5.01	Double nipple R1 x 80 with Loctite	139 000 26 747
5.02	Elbow A1-1-Zn-A	453 123
5.03	Double nipple R1 x 50 with Loctite	139 000 26 737
5.04	Flange W-MF	
	– 507 Rp1	605 233
	– 512 Rp1	605 228
5.05	Pressure test nipple G <sup>1</sup> / <sub>8</sub> A	453 001
5.06	O ring	
	– 57 x 3 W-MF 507	445 519
	– 75 x 3.5 W-MF 512	445 520
5.07	Multifunction assembly with gas pressure switch	
	– W-MF SE 507 S22 230V	605 320
	– W-MF SE 512 S22 230V	605 321
5.08	Solenoid coil	
	– W-MF 507 No. 032P 220-240V	605 255
	– W-MF 512 No. 042P 220-240V	605 257
5.09	Breather plug with filter element G <sup>1</sup> / <sub>8</sub>	605 302
5.10	Pressure switch GW 50 A5/1 5 ... 50 mbar with screws and O ring	691 378
5.11	O ring 10.5 x 2.25	445 512
5.12	Filter insert with seal	
	– W-MF 507	605 253
	– W-MF 512	605 254
5.13	Flange W-MF	
	– 507 Rp <sup>3</sup> / <sub>4</sub>	605 227
	– 507 Rp1	605 233
	– 512 Rp1	605 228
5.14	Double nipple	
	– R <sup>3</sup> / <sub>4</sub> x 50 with Loctite	139 000 26 727
	– R1 x 50 with Loctite	139 000 26 737
5.15	Isolating valve with TAE	
	– 998 N G <sup>3</sup> / <sub>4</sub> CE-TAS for Gas PN1	454 596
	– 998 N G1 CE-TAS for Gas PN 1	454 597
	Isolating valve without TAE	
	– 984 D Rp <sup>3</sup> / <sub>4</sub> PN 40/MOP5	454 660
	– 984 D Rp1 PN 40/MOP5	454 661
5.16	Pressure switch GW 50 A6/1 5 - 50 mbar*	691 381
5.17	Pressure switch NB 50 A2 5 - 50 mbar*	691 361

\* Only in conjunction with high gas pressure switch and low gas pressure switch.

**14 Notes**

**14 Notes**



<b>A</b>	
Access level .....	31, 37
Actuator.....	80
Adjust.....	70
Air damper .....	11, 48, 80, 81, 84
Air damper setting Standby.....	35
Air number .....	68
Air pressure .....	69
Air pressure switch.....	11, 66
Air regulator.....	84
Ambient conditions.....	17
Ammeter.....	40
Analogue module .....	35
Angle drive.....	81
Aperture .....	22, 23, 24
Appliance category.....	103
Approval data.....	17
<b>B</b>	
Ball valve .....	12, 21
Bar .....	102
Basic setting .....	76
Booming.....	99
Breather plug .....	86
Burner motor .....	13, 79
Burner starts .....	33
<b>C</b>	
Calculation.....	55, 63
Calorific value .....	46
Capacity graph .....	19
CO content .....	68
Coil.....	85
Combustion air .....	7
Combustion analysis .....	68
Combustion chamber pressure.....	19
Combustion head extension.....	22
Combustion heat rating .....	19, 48
Combustion limit .....	68
Combustion Manager .....	13, 88
Combustion setting.....	70
Commissioning.....	39
Condensate.....	9
Connection pressure .....	25, 41, 46
Connections.....	16
Consumption.....	17
Control unit.....	88
Conversion factor .....	69
Conversion table.....	102
Corrections.....	70
<b>D</b>	
Design lifespan .....	8, 72
Detailed fault codes .....	94
Diffuser .....	11, 48, 49
Dimensions.....	20
Display.....	30, 32
Display and operating unit .....	30
Disposal .....	9
double gas valve .....	12, 25
Drilling dimension drawing.....	22
Ducted air intake .....	7, 19
<b>E</b>	
Electrical connection.....	29
Electrical data .....	17
Electrode.....	77
electrostatic discharge .....	8
Emission.....	18
Emission class.....	18
ESD protective measures .....	8
Excess air.....	68
<b>F</b>	
F1.....	32
F9.....	32
Fan motor.....	79
Fan pressure .....	40
Fan wheel.....	11, 79
Fault .....	92, 95, 99
Fault codes.....	95
Fault memory.....	34, 35, 93
Fieldbus.....	16, 33
Fieldbus address.....	35
Fieldbus module.....	35
Filter .....	12, 87
Filter insert .....	87
Flame failure .....	36
Flame signal .....	13, 30, 40
Flame tube .....	22
Flue gas losses.....	68
Flue gas measurement.....	68
Flue gas temperature .....	68
Fuel.....	17
Full load.....	53, 61
Fusing .....	16, 17, 91
<b>G</b>	
Gas butterfly valve .....	12
Gas butterfly valve setting Standby.....	35
Gas connection pressure.....	25, 41
Gas consumption.....	33
Gas family .....	103
Gas filter.....	12, 87
Gas isolation valve .....	12, 21
Gas meter .....	33, 35
Gas pressure switch .....	12, 27
Gas setting pressure.....	46
Gas supply .....	25
Gas temperature .....	69
Gas throughput .....	69
Gas valve train .....	23, 26
Guarantee.....	6
<b>H</b>	
H2.....	17
Heat exchanger .....	22
High gas pressure switch .....	13, 65

15 Key word index

Hours run .....	33	Operating volume .....	69
Housing cover.....	78	Operational failure .....	71
Humidity .....	17	Outputs .....	16
Hydrogen .....	17, 53, 61, 68		
<b>I</b>			
Idle time.....	71	Pa.....	102
Ignition electrode .....	77	Parameter level.....	35
Ignition speed .....	62	Partial load.....	56, 64
Ignition unit .....	13	Pascal .....	102
Indicating bolt .....	49	Personal protective equipment.....	8
Info button.....	30	Post purge air damper setting .....	36
Info level .....	33	Post-purge time.....	15, 35
Initialisation time .....	15	PPE .....	8
Inputs .....	16	Pre-purge time.....	15
Installation.....	22, 23	Pressure measuring device .....	40
Installation elevation .....	17, 19	Pressure regulator .....	12, 25
Installation location .....	7, 22	Pressure switch.....	11, 49, 66
Installation position.....	25	Problem solving.....	99
Intake housing.....	84	Program sequence .....	14, 100
Interface .....	16	Protective equipment.....	8
Internal unit fuse .....	91	Pulsating .....	99
Ionisation current.....	40		
Ionisation electrode .....	13, 77	<b>R</b>	
<b>L</b>			
Liability.....	6	Rating .....	19
Lifespan.....	8, 72	Refractory .....	22
Linearisation .....	55, 63	Remote reset.....	29
Lockout.....	92, 95	Repetition counter .....	94
Low gas pressure switch/valve proving gas pressure switch.....	12, 65	Reset.....	93
<b>M</b>			
Mains voltage .....	17	Reset button.....	30
Maintenance position.....	78		
mbar .....	102	<b>S</b>	
Measuring device.....	40	Safety measures.....	8
Mechanical noises .....	99	Safety symbols .....	7
Minimum speed .....	62	Safety time.....	15
Mixing head .....	11, 48, 75, 76	Serial number.....	10
mixing pressure .....	40	Service contract .....	72
Monitoring current .....	40	Service interval .....	72
Motor.....	13, 79	Service level .....	34
Motor W-PM.....	17	Service plan.....	74
Multifunction assembly .....	12	Service position.....	78
<b>N</b>			
Name plate .....	10	Servicing .....	72
Noise emission values .....	18	Setting diagram .....	48
Nominal diameter .....	46	Setting dimension .....	76
<b>O</b>			
OFF function .....	30	Setting pressure.....	46
Operating level .....	30	Setting screw.....	76
Operating mode .....	14	Shutdown .....	71
Operating panel .....	13, 92	Software.....	31
Operating problems .....	99	Solenoid coil .....	85
Operating status .....	31, 94, 100	Sound levels.....	18
		Sound power level .....	18
		Sound pressure level .....	18
		Soundness test .....	42
		Spares .....	111
		Speed standardisation.....	59
		Stability problems .....	99
		Standard volume .....	69
		Standards .....	17
		Starts .....	33
		Sticker .....	90
		Storage.....	17

Symbol..... 7

**T**

Temperature ..... 17

Test points ..... 44

Test pressure ..... 42

Transport..... 17

Type ..... 10

Type key ..... 10

Type of Gas..... 17, 103

**U**

Unit of pressure ..... 102

**V**

Valve proving..... 12, 65

Valve train ..... 21, 25, 26, 46

VisionBox ..... 31

Voltage supply ..... 17

**W**

Warning label..... 7

Weight..... 21

when gas can be smelled ..... 7

Das ist Zuverlässigkeit. C'est la fiabilité. That's reliability. Questa è affidabilità. 信頼性とは、ころいろものです。Това е надеждност. Ez a megbízhatóság. Đó là sự đáng tin cậy. اردن رقابارت المؤمنان است To je zanesljivost. Güvence budur. Αυτό σημαίνει αξιοπιστία. 그것은 바로 신뢰성입니다. To je spoľahlivosť. Dat is betrouwbaarheid. Tämä on luotettavuutta. هذه هي الوثوقية See on usaldusväärsus. Pouzdana tvrtka. To jest niezawodność. นั่นคือความเชื่อถือได้ Це надійність. Isto é fiabilidade. To je spolehlivost. यही विश्वसनीयता है. Det är pålitlighet. זאת אמינות. Esto es fiabilidad. Это надёжность. Itulah kepercayaan. 值得信赖。Is é sin iontaofacht. Iyan ang maaasahan. Aceasta este fiabilitatea. اتى ن س و شو سه مو Tai - patikimumas. Det er pålitelighet. Tā ir uzticamība. Sa se fyab. To je pouzdanost. La fiabilité avant tout. Det er pålidelighed.